

## “EFESTO-SZ” Safety Light Curtain with multi beams

### Instruction use and maintenance

---

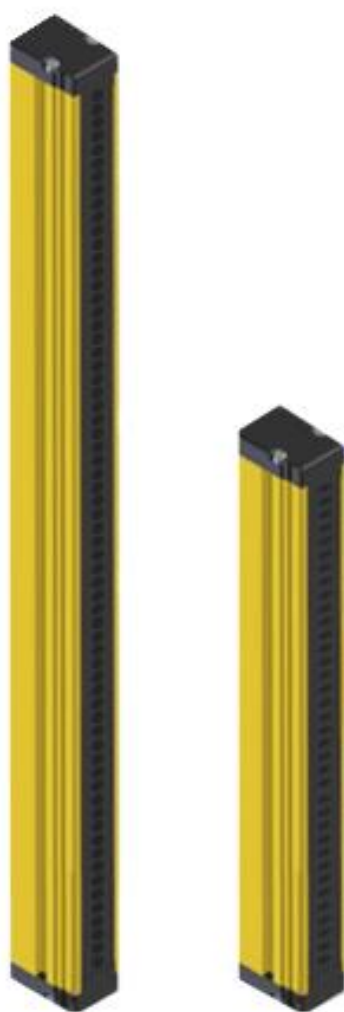

# IMPORTANT REMARKS ON SAFETY

---

## EFESTO-SZ - ORIGINAL INSTRUCTION

As this device, for the safety of operators working on dangerous machinery, it is necessary that an authorised person should carry out the installation carefully while making notes and maintain such records for future instruction and maintenance.

The safety light curtain forms only one link of the safety system.

Therefore, complete system performance remains the responsibility of the machine manufacturer or end user.

Please observe all technical details and recommendations reported in this installation/instruction manual without exception and with strict adherence to all applicable local, National and International Safety Standards and guidelines which may apply to the machines.

**GREIN is not responsible for any dangerous occurs to a not correct employ of the product.**

## Summary

GENERAL INFORMATIONS	pag. 4
TERMS AND DEFINITIONS	pag. 4
TECHNICAL CARATTERISTICS AND FUNCTIONS	pag. 5
INSTALLATION GUIDELINES	pag. 6
DETERMINATION OF SAFETY DISTANCE	pag. 7
MINIMUM DISTANCE TO AVOID THE REFLECTIONS	pag. 9
MECHANICAL MOUNTING	pag. 10
GROUPING OF BARRIERS	pag. 11
MASTER / SLAVE BARRIERS	pag. 12
MODELS AND E FUCTION	pag. 13
WIRING CONNECTIONS	pag. 14
CONNECTING EXTERNAL CONTACTORS	pag. 17
EMITTER CONNECTIONS AND FUNCTIONS	pag. 18
RECEIVER CONNECTIONS AND FUNCTIONS	pag. 18
INDICATION AND DIAGNOSTIC	pag. 21
SERVICE AND TEST	pag. 24
SETTING UP AND TEST	pag. 25
LIST OF MODELS AND CHARACTERISTICS	pag. 26
RESPONS TIME FOR MASTER / SLAVE, MTTFd	pag. 34
ACCESSORIES - MIRRORS	pag. 35
MOUNTING BRACKETS	pag. 40
CONNECTION CABLES	pag. 43
RELAYS MODULE DIN RAIL	pag. 44
EXTERNAL MODULES BOX	pag. 46
WARRANTY	pag. 47
UE DECLARATION OF CONFORMITY	pag. 48

## GENERAL INFORMATIONS

The EFESTO-SZ light curtain is a optoelectronic system with multi beams ( **Electro-Sensitive Protective Equipment** ) type 4 for the protection of body to prevent accident on the machine on dangerous plants in accordance with International safety standards.

EFESTO-SZ is formed of an emitter and a receiver unit synchronized through a optic link. The safety out-put are at solid state with possibility to transform on power with relays inserted on special module.

The wide range of model permit the employ on every field of industrial automation supplying the protection of the fingers, hand, arm, body, for the movement on dangerous area.

The principal application are presses, robotized areas, highly automated equipment, and many others.

The series EFESTO-SZ is divided in different models based on the functions implemented.

This system allows the customer to choose the most adequate model of barrier in according to his requirements. To complete the range are available some interconnection modules to connect the barrier without to pass to the general panel of machine.

## TERMS AND DEFINITIONS

<b>OSSD0</b>	Safety output channel zero.
<b>OSSD1</b>	Safety output channel one.
<b>OSSD STATO ON</b>	Condition on which the output permits the flow of current.
<b>OSSD STATO OFF</b>	Condition on which the output do not permit the flow of current.
<b>EDM</b>	External Device Monitor.

**RESET** OSSD restart from OFF to ON.

**Protective height PH**  
It is the zone in which the test rod will stop the barrier.

**Sensitive height SH**  
It is the zone covered by the beams.

**A** Active part of the lens.

**B** Beam spacing in mm.

**Resolution d**  
It is the minimum object detected on protected area, Is the dimension necessary for the obscuration of two adjacent beams.  
 $d = A + B.$

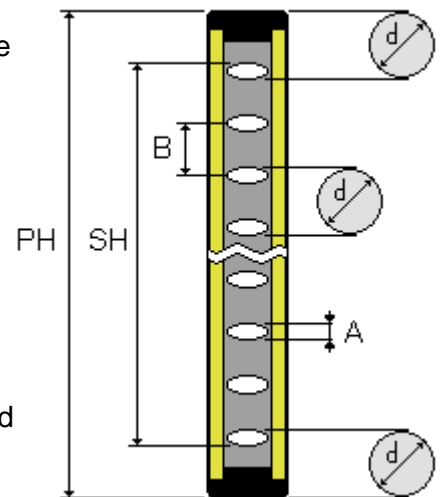

## Technical characteristics

<b>Synchronization Tx Rx</b>	Optical
<b>Total aperture angle</b>	5°
<b>Wave length</b>	940 nm
<b>Resolutions</b>	14, 20, 30, 40, 55, 65, 125, 135, 306, 315 mm
<b>Maximum range</b>	6 - 15 - 30 - 60 m depending from the resolution
<b>Protected height</b>	from 200 mm to 3000 mm
<b>Maximum speed</b>	3,3 m/s ( of test rod 150 mm length )
<b>Output</b>	2 PNP - 500 mA short circuit and overload protected
<b>Connections</b>	M12 5 / 8 poles in functions of the model and options
<b>Power supply</b>	24 Vdc ± 10%
<b>Consumption tx + rx</b>	400 mA, load excluded
<b>Response time</b>	From 5 to 30 ms depending to number of beams
<b>Max connections lenght</b>	100 m
<b>Body</b>	Extruded aluminium, 36 x 50, RAL 1.021
<b>IP protection degree</b>	IP 65
<b>Relative umidity</b>	5 - 95%
<b>Working temperature</b>	-10 ÷ 65 °C non condensing
<b>Storage temperature</b>	-20 ÷ 70 °C
<b>Safety level</b>	Ttpe 4 - SIL 3 - SILCL 3 - PL e – Cat. 4

## Functions available

<b>Reset</b>	Selection of the restart of the barrier
<b>Type</b>	Automatic or manual
<b>Restart time</b>	100 ms
<b>EDM</b>	External Device Monitor
<b>TEST</b>	Simulation of interruption of light curtain beams barrier, to facilitate the monitoring of the safety of the machine
<b>BARGRAPH</b>	3 led for alignment and indications

## INSTALLATION GUIDELINES

## Correct Installation



Frontal protection



Vertical and horizontal protection



Oblique protection

## Incorrect installation



Insertion into the danger zone under the barrier

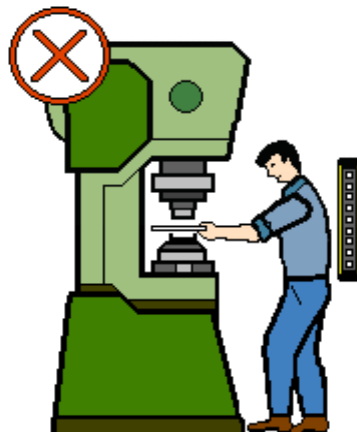

Insertion between the barrier and dangerous zone

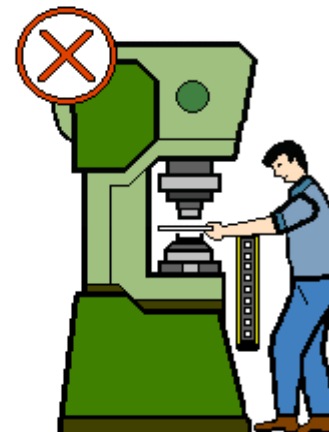

Insertion into the dangerous zone above the barrier

Refer to the standard EN ISO 13855 for a correct installation of the safety device

## DETERMINATION OF SAFETY DISTANCE

Before of the installation it is necessary to calculate the safety distance in order to allow the stop of the machine before the operator or part of his body enter in the dangerous area ( as described in ISO 13855).

### Definitions:

- S** safety distance in mm
- T1** response time of machine in ms
- T2** response time of curtain in ms  
(see TX / RX label)
- d** resolution of the system in mm

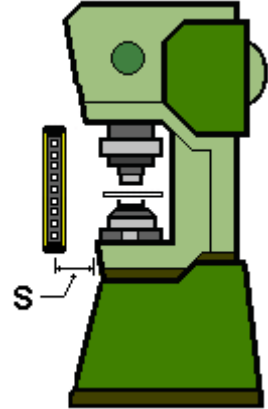

### Vertical installation

#### Models with resolution up to 40mm

The following formula is valid for a distance S included between 100 and 500 mm:

$$S = 2 (T1 + T2) + 8 (d - 14)$$

If S results more of 500mm, use the following formula:

$$S = 1,6 (T1 + T2) + 8 (d-14)$$

#### Models with resolution more than 40 and up to 90 mm

$$S = 1,6 (T1 + T2) + 850$$

The highest beam must be placed at a minimum height of 900 mm from the installation plane of the machine, while the inferior beam must be at a height less than 300 mm

#### Models with resolution more than 90 mm

$$S = 1,6 (T1 + T2) + 1.200$$

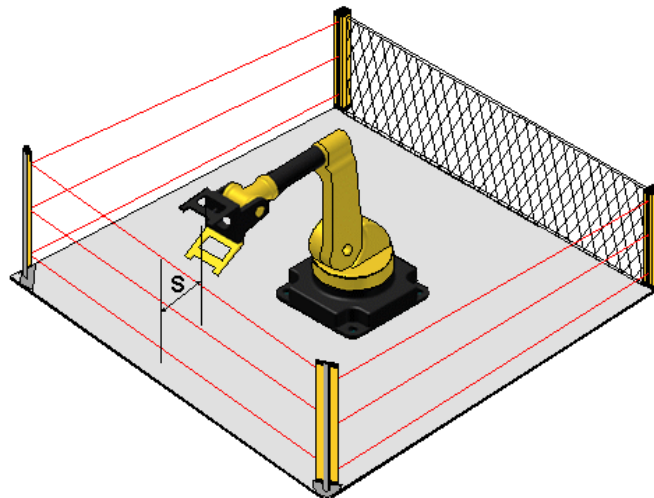

## DETERMINING THE SAFETY DISTANCE

### Horizontal installation

For all types of light curtains with horizontal installation, to detect intrusion of legs and body, the distance **S** shall be calculated using the formula :

$$S = 1,6 (T1 + T2) + K$$

where:

**K** = (1200 - 0.4 H ) must be > 850 mm  
**H** = height of curtain in mm from ground

**H** must be lower than the working plane, and in any case don't higher than 1.000 mm

Example using a light curtain with resolution 55 mm, height of working plane 800 mm:

**T1** = 100 ms  
**T2** = 10 ms  
**H** = 750 mm  
**K** = 1200 - 0.4 x 750 = 900 mm  
**S** = 1.6 (100 + 10) + K = 1076 mm

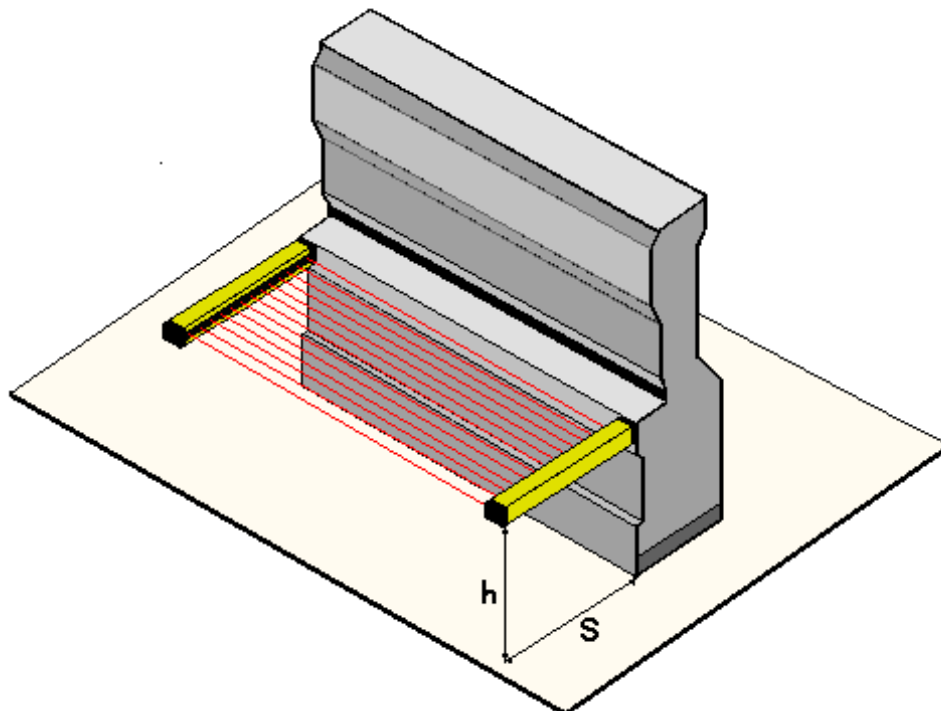



## MINIMUM DISTANCE TO AVOID PASSIVE REFLECTIONS

The beam angle of optic and alignment tolerance for emitter and receiver is 5 degrees. Since reflective surfaces near the detection zone can cause reflections and therefore non-detection of an object, a minimum distance **A** to the optical axis, should be observed according to the following formula:

$$A = 44 L \quad \text{where } A \text{ is in mm, } L \text{ is in m}$$

**A** should never be less than 131 mm

To verify the above, after the installation of the light curtain, is necessary to pass the test rod through the detection zone, near the emitter, the receiver and in the middle of the detection zone, verifying that :

If selected the automatic restart      the LED OS OFF      should remain always ON;  
 If selected the manual restart      the LED BMS      should remain always OFF.

If the indications are not as described above, there is a hole in the detection zone due to reflection.  
 Modify the position of the barrier to avoid the reflection.

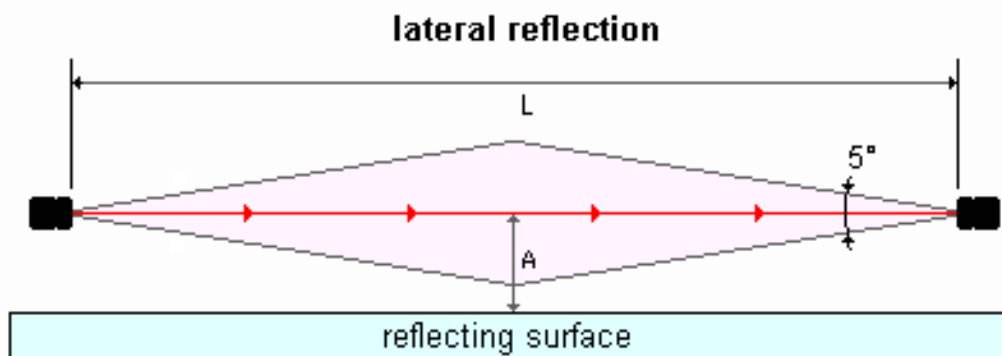
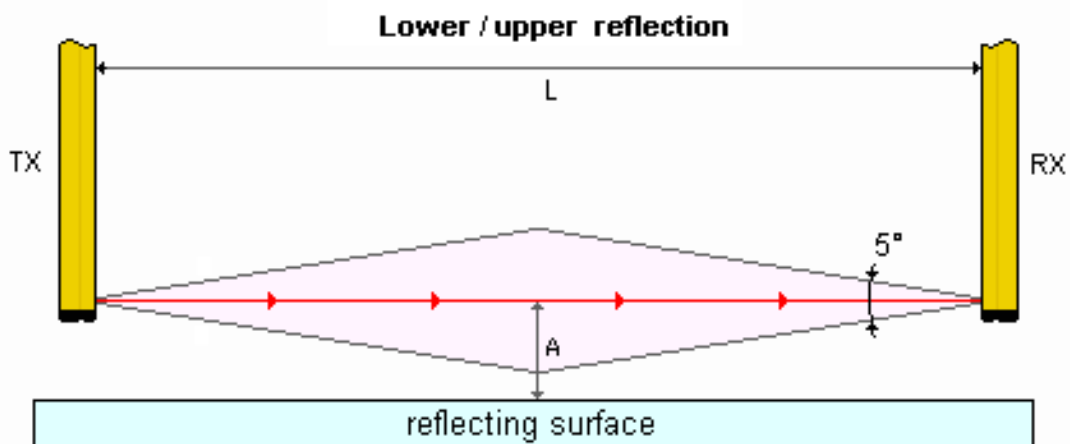

## MECHANICAL ASSEMBLY

During the installation it is necessary to verify the right position of emitter and receiver to check that they are in the same plane and axis as shown on the following drawings.

Side view :

Correct

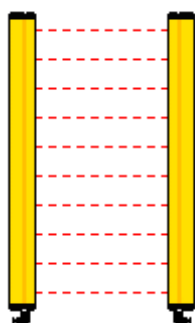

Angular mistake

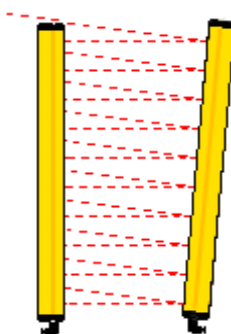

Axial mistake

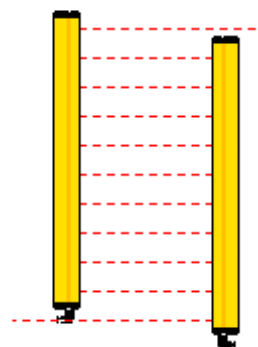

Top view :

Correct



Angular mistake



Axial mistake



### GROUPING OF LIGHT CURTAINS

**Linear assembly**, to increase the protected height

To avoid the reciprocal interference between 2 light curtains it is necessary that the emitter and receiver are mounted on opposite sides.

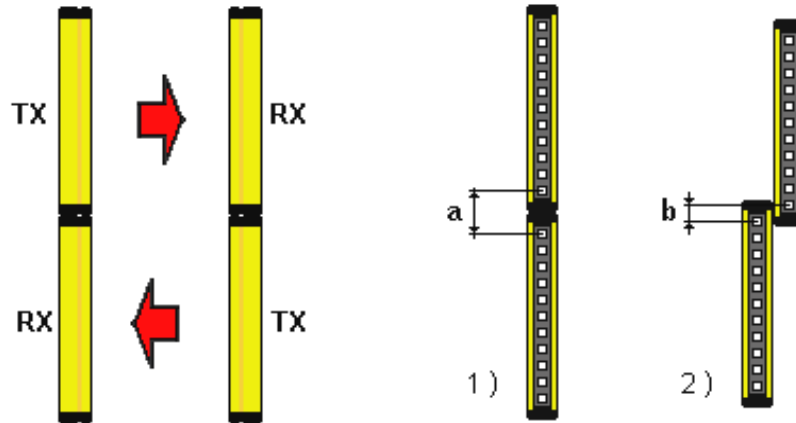

- 1) Example of two light curtains on the same axis with a non-constant resolution in the joint point
- 2) Example of two light curtains no aligned to maintain constant resolution in the joint point.

Suggestions to avoid interference between light curtains assembled in line in case of long distances or protected machines installed in series:

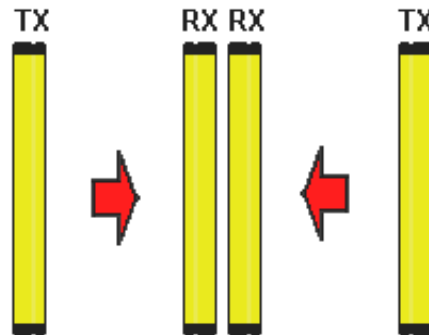

The light curtain can work on vertical position or upside-down.

Don't turn the transmitter in the opposite direction of the receiver, it changes the protected field.

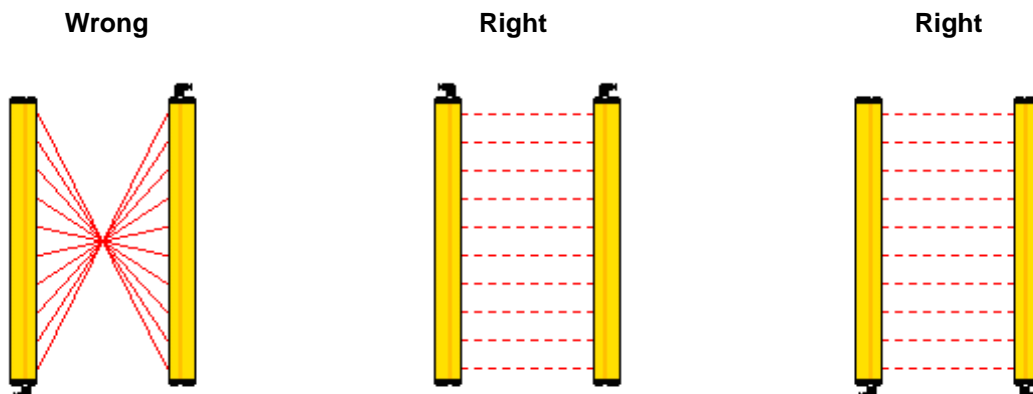

## LIGHT CURTAINS FOR ANGLED APPLICATION "L" SHAPE master and slave

Where the safety distance is particularly long (for example using large presses) it is necessary that nobody can enter in the dangerous area at the restart of the machine. This problem can be solved by installing the angled version light curtain, which consists of a vertical unit (MASTER) and a horizontal unit (SLAVE) used to stop behind protection.

The vertical light curtain is provided with one fixed cable of length max. 500 mm and a male connector. The horizontal light curtain is provided with female connector only.

Particular attention must be taken during the installation, insuring that on the point where the light curtains meet, the resolution must be the same as the horizontal light curtain (see drawing below).

As the two units (vertical and horizontal) works electrically as one light curtain, attention must be taken during the installation, the system will operate only if all the vertical / horizontal - emitter / receiver are perfectly aligned. The bargraph in the master and slave barriers help with the alignment operation.

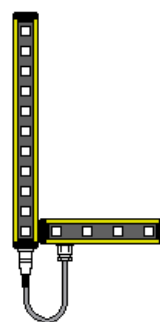
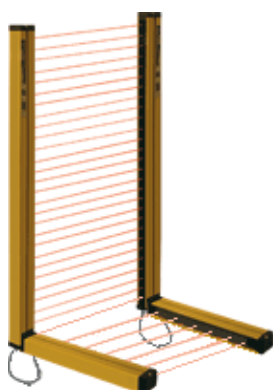
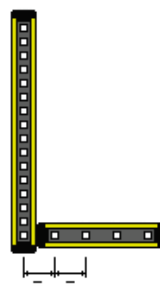

Master / slave connection

### Model and function

All models have the following features :

- TX with M12 4 poles connector and test input.
- RX with 2 solid state PNP output.
- Automatic reset.
- Bargraph with 3 led for alignment and signalling.

### Functions and connections available of different models

Model	Function available		RX Connectors	
	RM	EDM	M12 5P	M12 8P
EFSZ - a ...			•	
EFSZ - b ...	•	•		•

... optical code

### LEGEND

RM                Manual reset  
 EDM             External Device Monitoring

### RECEIVER CONNECTIONS

M12-5P          Connector M12 - 5 Poles - male  
 M12-8P          Connector M12 - 8 Poles - male

Available connection with M12 back cable, see pag. 26 and code pag. 34.

### Optic

optic	Resolution	Min. Range	Max range
__ A	14 mm	0.5	6 m
__ AL	20 mm	2 m	15 m
__ B	30 mm	0.5m	15 m
__ BL	40 mm	6 m	30 m
__ C	55 mm	0.5m	15 m
__ CL	65 mm	6 m	30 m
__ D	125 mm	0.5m	15 m
__ DL	135 mm	6 m	30 m
__ E	306 mm	0.5m	15 m
__ EL	315 mm	6 m	30 m

\_\_ protection height code

**Note** are available special versions \_\_DLL and \_\_ELL with range from 6 up to 60 m.

## Wiring connection

### Warning on connection cables

- 1 – Use cables with section of 1 mm<sup>2</sup> for length connection more than 50 m.
- 2 – The units TX / RX shall be connected to the ground (PE).
- 3 – All the cables shall follow different way from those of power.
- 4 – The power of the barrier should be separated from that of equipment dedicated to the control of power equipment, such as inverters.
- 5 – If there is the possibility to damage the cables, take care to protect them against crushing or cutting.
- 6 – If shielded cables are used, the shield must be earthed (PE).

### Emitter connection

Emitter EFSZ - ... -						
Pin N	Wire color	Function	Description	Type	Level	
M12 4 poles						
1	Brown	+24V	Positive power supply	IN	+24 Vdc +/- 10%	0,5A
2	White	TEST	TEST signal	IN	0 - 24 Vdc	10mA
3	Blue	GND	0V power supply	IN	0V	
4	Black	PE	Ground	-	-	

Example of connection

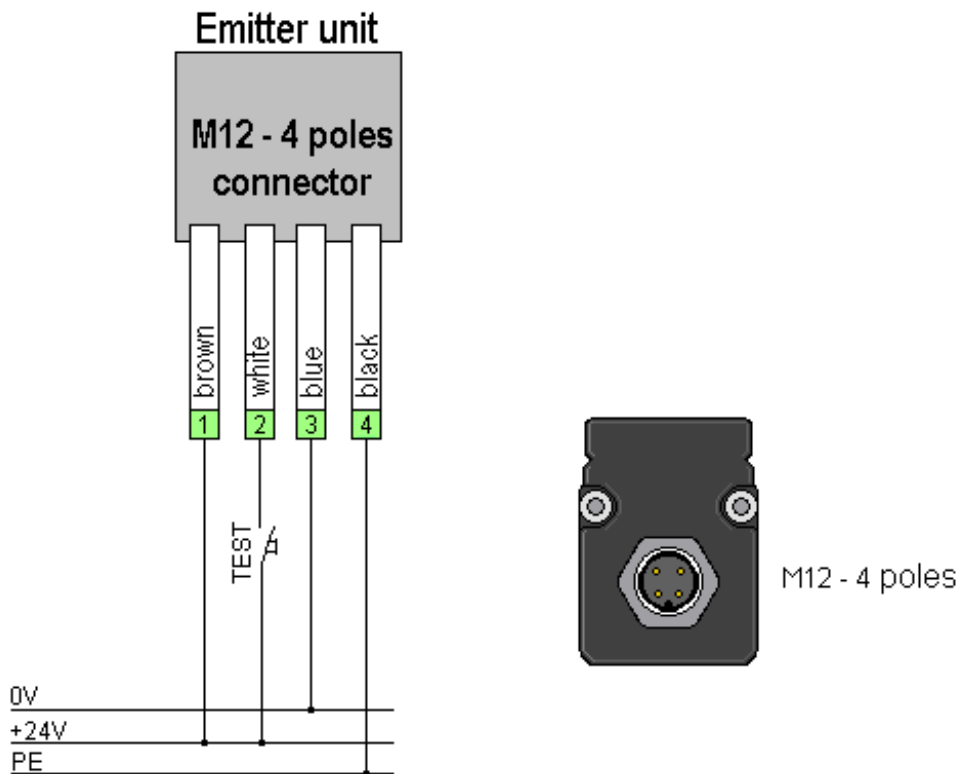

EFSZ- a CONNECTION

Receiver EFSZ-a - ... -						
Pin N	Wire color	Function	Description	Type	Level	
M12 5 poles						
1	Brown	+24V	Positive power supply	IN	+24 Vdc +/- 10%	1A
2	White	OSSD-0	Static safety output 0	OUT	0 - 24 Vdc	0,5A max
3	Blue	GND	0V power supply	IN	0V	
4	Black	PE	Ground	-	-	
5	Grey	OSSD-1	Static safety output 1	OUT	0 - 24 Vdc	0,5A max

Example of connection

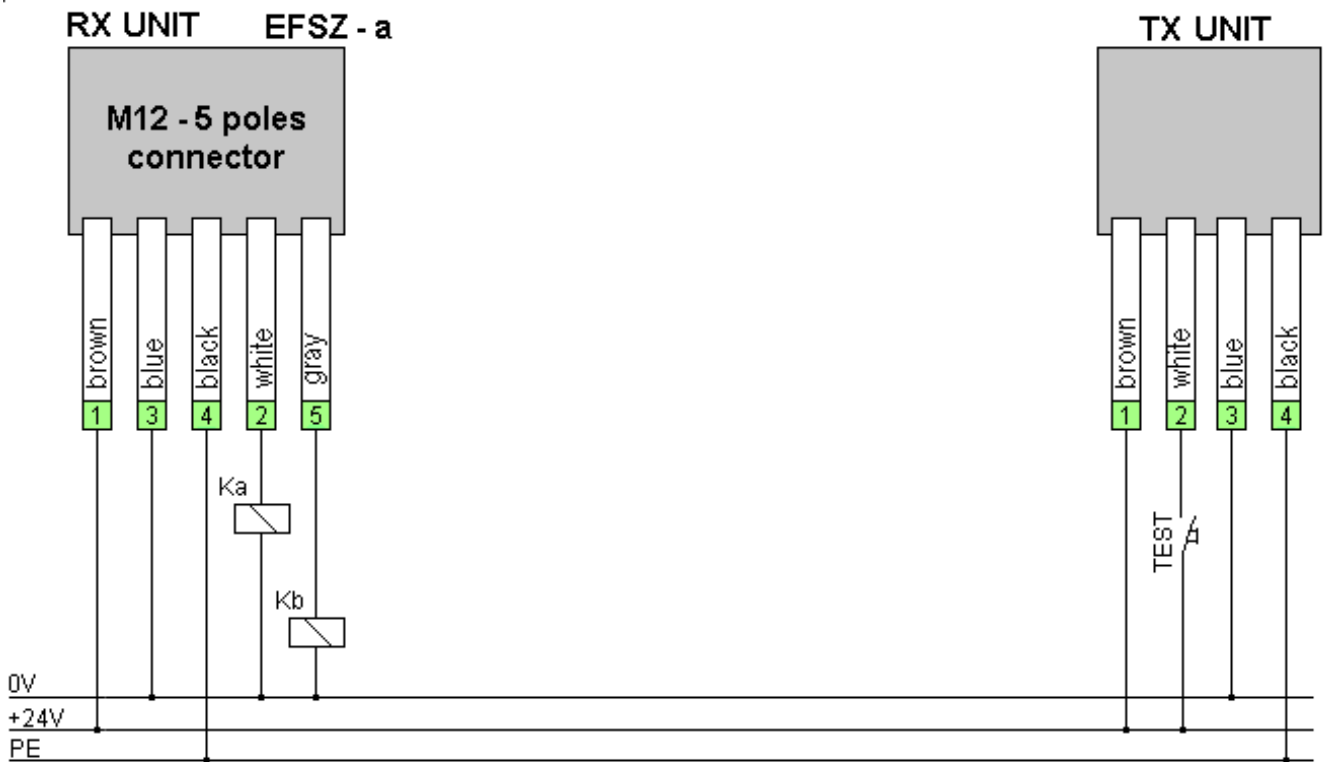

M12 5 poles

This version does not include contactor control. The OSSD outputs must be connected to the machine via a safety module or safety PLC.

**EFSZ- b CONNECTION**

Receiver EFSZ-b - ... Reset + Edm						
Pin N	Wire color	Function	Description	Type	Level	
M12 8 poles						
1	White	OSSD-0	Static safety output 0	OUT	0 - 24 Vdc	0,5A max
2	Brown	+24V	Positive power supply	IN	+24 Vdc +/- 10%	2A
3	Green	START ENABLE	Selection of manual or automatic reset	IN	0 - 24 Vdc	10mA
4	Yellow	START	Input of external RESET	IN	0 - 24 Vdc	10mA
5	Gray	OSSD-1	Static safety output 1	OUT	0 - 24 Vdc	0,5A max
6	Pink	EDM	External device monitor input	IN	0 - 24 Vdc	10mA
7	Blue	GND	0V power supply	IN	0V	
8	Red	PE	Ground	-	-	

Example of connection

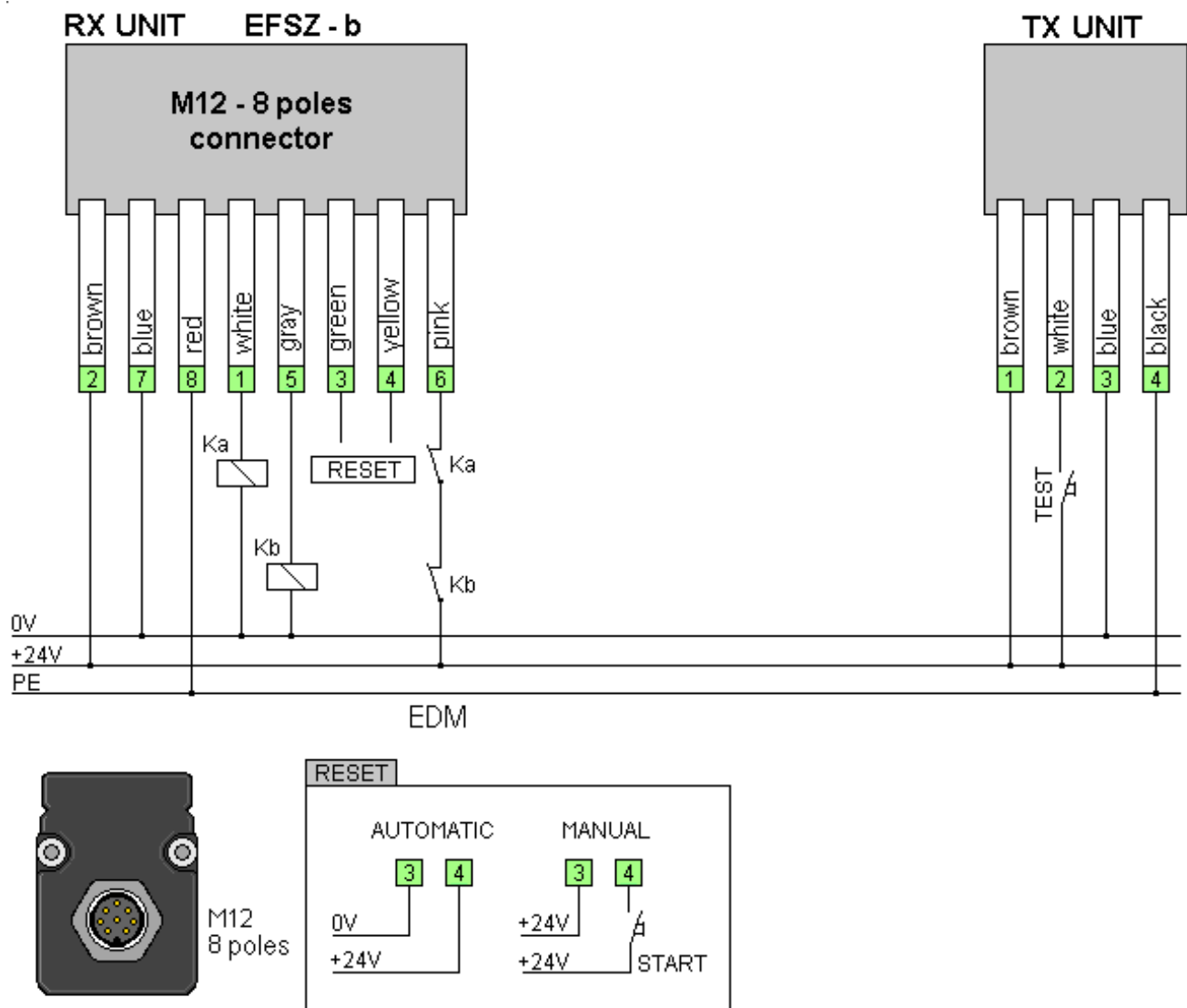



## EXTERNAL CONTACTORS CONNECTION

The diagram below shows the connection of the external contactors to increase the number of contacts or the necessary current to the load and the connection contacts of the feedback signal to the EDM (External Device Monitor, pink wire).

Only series barriers EFESTO-SZ-b with EDM (external device monitor) can be used to carry out properly the application.

The voltage supplied by the EFESTO-SZ light curtain is 24 V with a maximum current of 0.5 A. Select the external contactors on the basis of these values.

In the example below, a EFESTO-SZ model B light curtain with setting the automatic reset it connected to Ka and Kb contactors.

The normally closed contacts of external contactors are connected in series, with the voltage of + 24V and the EDM input (pink wire) of the light curtain.

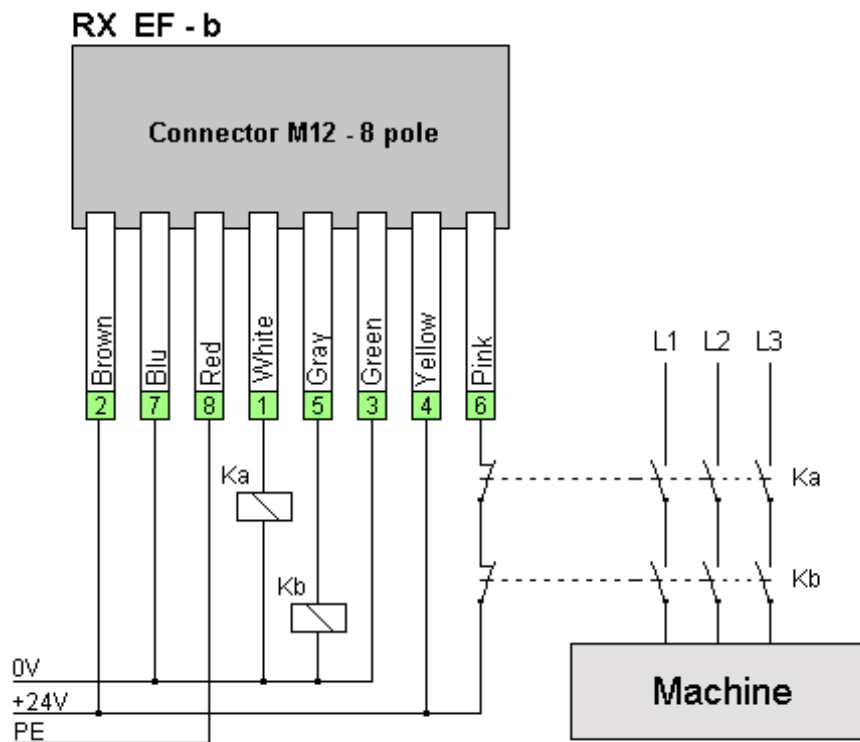

## EMITTER CONNECTIONS AND FUNCTIONS

<b>+24 Vdc</b>	+24 Vdc Power supply
----------------	----------------------

Connect to +24Vdc  $\pm 10\%$  1A power supply.

The current of 1A is the supply current for all type of EFESTO-SZ light curtains

<b>0 Vdc</b>	0 Vdc Power supply
--------------	--------------------

Connect to 0 Vdc of 24 Vdc power supply.

<b>PE</b>	Protective Earth
-----------	------------------

Connect to the ground of machine.

<b>TEST</b>	TEST input
-------------	------------

This signal simulates the interruption of the beams to check the safety chain.

During the test, OSSD0 and OSSD1 are in OFF state and the POWER / TEST indicator blinks.

The TEST is active when connected to +24 Vdc.

If connected to 0 V or not connected the test is not active, the POWER / TEST indicator is OFF.

## RECEIVER CONNECTIONS AND FUNCTIONS

Some of the following functions can be present or not, depending of the model ordered.

### Power supply

<b>+24 Vdc</b>	+24 Vdc Power supply
----------------	----------------------

Connect to +24Vdc  $\pm 10\%$  2 A power supply.

The current of 1A is the supply current for the EFESTO-SZ light curtains.

To calculate the total current is necessary include:

- OSSD0 e OSSD1 absorbed current ( max 0.5A each );
- STATUS lamp absorbed current ( max 0.2A );
- MUTING lamp absorbed current (max. 0.5 A).

<b>0 Vdc</b>	0 Vdc Power supply
--------------	--------------------

Connect to 0 Vdc of 24 Vdc power supply.

<b>PE</b>	Protective Earth
-----------	------------------

Connect to the ground of machine.

**Outputs**

<b>OSSD-0</b>	Safety output 0
<b>OSSD-1</b>	Safety output 1

Static safety PNP outputs, OSSD0 channel 0 and OSSD1 channel 1.

Use the OSSD outputs to stop the dangerous movement of the machine through contactors with guided contacts controlled by the barrier, or by safety relay module or safety PLC.

The OSSDs outputs go in ON state ( +24 V ) if are satisfy the following conditions:

- barrier aligned and activated by reset command,
- protected area free,
- correct connections and no internal fault.

The barriers with MUTING function can activate the OSSDs also using the guard override function.

The OSSD outputs go or remain in OFF state ( 0 V ) if is not satisfied one or more of the above conditions.

The outputs are dynamically monitored. To check the absence of fault, when the OSSDs are in ON state, will be switched in OFF state for 0,2 ms, with a period = response time – 1 ms

**ELECTRICAL CHARACTERISTICS OF THE OUTPUTS**

DESCRIPTION	
Nominal output current for resistive load	500 mA
Max. output current for resistive load	500 mA
Nominal output current for inductive load	500 mA
Max. output current for inductive load	500 mA
Max. capacitive load with no resistive load applied	1 µF
Max. capacitive load with resistive load of 48 OHM applied	2 uF
Max. output voltage in OFF-State	0.1 V
Max. output current in OFF-State	10 µA ( leakage current )
Max. resistance between the OSSDs outputs and the load	22 Ω

<b>OSSD-S</b>	Output for OSSD state
---------------	-----------------------

PNP output to indicate the state of the OSSDs outputs.

This output is 24 V when the OSSDs are active.

<b>EDM</b>	Input for External Device Monitor
------------	-----------------------------------

Monitoring of external contactors.

Allow to check the external contactors using their series of the NC contacts.

The contactors shall have the forced guided contacts.

With OSSD in OFF state on the EDM input shall be present 24 V.

With OSSD in ON state on the EDM input shall be present 0 V.

The barrier checks the EDM input after the power on, and at every change state of the OSSDs.

The barrier checks the time of ON / OFF commutation, it shall be less than 500 ms.

**If the EDM is not used, connect it to the OSSD 0 output.**

**Reset**

<b>START-E</b>	Input for reset selection
<b>START</b>	Input for restart pushbutton

**AUTOMATIC RESET**

With the selection of the automatic reset, the OSSDs outputs follow the state of the barrier.

When the protected area is free, automatically the OSSDs go in ON state.

Take into consideration that in this case there is not the start interlock. If this function is necessary, verify that other means are present to stop the machine at the power on.

**MANUAL RESET**

One push button NO shall be activated to start or re-start the OSSD0 and OSSD1 after the interruption of the beams or when the ESPE is turned on at first time.

This pushbutton must be located outside the dangerous area and shall not be possible to activate it from inside of the dangerous area. It shall be located where is possible to check the dangerous area. The manual reset has the function of start interlock.

This system shall be utilized when the barrier is employed for the protection of a dangerous passage.

The following table show the reset setup.

<b>START- E</b>	<b>START</b>	<b>Function selected</b>
0 V	24 V	AUTOMATIC RESET
24 V	NO / 24 V	MANUAL RESET

## INDICATIONS and DIAGNOSTIC

Below are the main functions related to each indicator and its status.

### TRANSMITTER

<b>FAULT</b>	RED - Fault
--------------	-------------

If the indicator is blinking, the light curtain is stopped due to an internal failure. In this case contact the technical support.

<b>POWER-TEST</b>	YELLOW - Power On & Test
-------------------	--------------------------

If the indicator is ON, the power supply is connected correctly. If the indicator blinks, the TEST function is active.

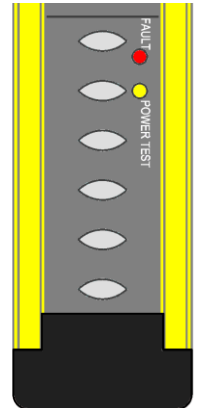

### RECEIVER

<b>OS OFF</b>	RED - State of OSSD0 e OSSD1
---------------	------------------------------

The OSSD0 and OSSD1 outputs are in OFF state.

<b>OS ON</b>	GREEN - State of static OSSD0 e OSSD1
--------------	---------------------------------------

The OSSD0 and OSSD1 outputs are in ON state.

<b>BMS</b>	YELLOW - Wait external reset
------------	------------------------------

If all beams of the sensitive zone are aligned and the manual RESTART is selected, the indicator is ON. After pressed and released the restart button, the indicator is OFF.

<b>FAULT</b>	RED - Fault
--------------	-------------

If the indicator is ON, the light curtain is stopped due to an internal failure. In this case contact the technical support.

<b>ALN1</b>	YELLOW - BARGRAPH Led 1
<b>ALN2</b>	YELLOW - BARGRAPH Led 2
<b>ALN3</b>	YELLOW - BARGRAPH Led 3

The three LEDs provide indications on the beams alignment. This simplifies the alignment of the light curtain, particularly in case of difficult installations, for example with the use with mirrors or on long range.

To each indicator is associated a percentage of beams aligned.

The indications given are summarized in the following table.

ALN1	ALN2	ALN3	DESCRIPTION
OFF	OFF	OFF	No beam is alignment or the first beam is interrupted
BLINK	OFF	OFF	The number of the aligned beams is less than 1/3 of total beams
ON	BLINK	OFF	The number of the aligned beams is between 1/3 and 2/3
ON	ON	BLINK	The number of aligned beams is between 1/3 and up to maximum
ON	ON	ON	All beams are aligned

The blink period is 1 second.

When the OSSDs switch from OFF to ON state, the alignment indicators will turn OFF.

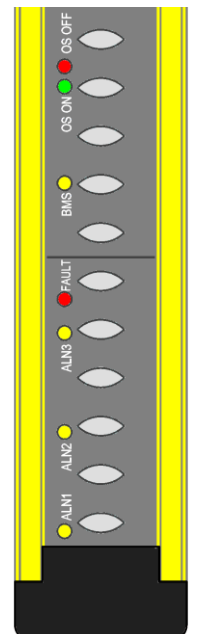

## MASTER-SLAVE

In the master / slave barrier models, to facilitate the alignment of the slave part (horizontal) it is provided an additional bargraph alignment. The bargraph of the master performs as previously described.

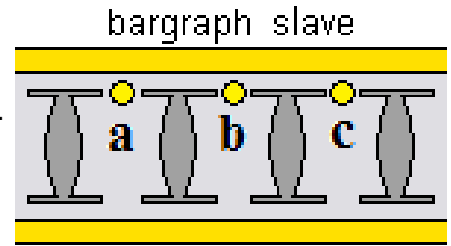

When the master (vertical) is fully aligned, the first indicator of the slave (horizontal) start flashing at a rate of a brief flash and a pause (FLASH).

When at least one beam of the slave is aligned, the bargraph provides the following information:

a	b	c	DESCRIPTION
FLASH	OFF	OFF	No aligned beams or first beam obscured
BLINK	OFF	OFF	The number of the aligned beams is less than 1/3 of total beams
ON	BLINK	OFF	The number of the aligned beams is between 1/3 and 2/3
ON	ON	BLINK	The number of aligned beams is between 1/3 and up to maximum
ON	ON	ON	All beams are aligned

When the barrier is fully aligned, the LEDs of the master and the slave are switched off.

### Further indication to find the faults.

#### MANUAL and AUTOMATIC RESTART

If an error occurs in the reset setting, **OS OFF** and **FAULT** indicator are ON and **ALN1** indicator blinks. The light curtain is locked.

Turn OFF the light curtain, check the reset settings and then turn ON the barrier.

The main causes can be :

- Restart wires not connected properly;
- push button of manual reset is NC instead of NO;
- push button of manual reset pressed during the turn on of the barrier.

**OSSD 0 / OSSD 1**

If an error occurs on the OSSD output, OS OFF and FAULT indicators are ON and ALN2 indicator blinks. The light curtain is locked. Turn OFF the barrier, check the OSSD output connections and then turn ON the power supply.

The main causes can be :

- Short circuit between OSSDs;
- OSSD connected to +24 V or 0 V;
- capacitive load beyond the limit, excessive cable length:
- wrong connection of the outputs;
- internal fault.

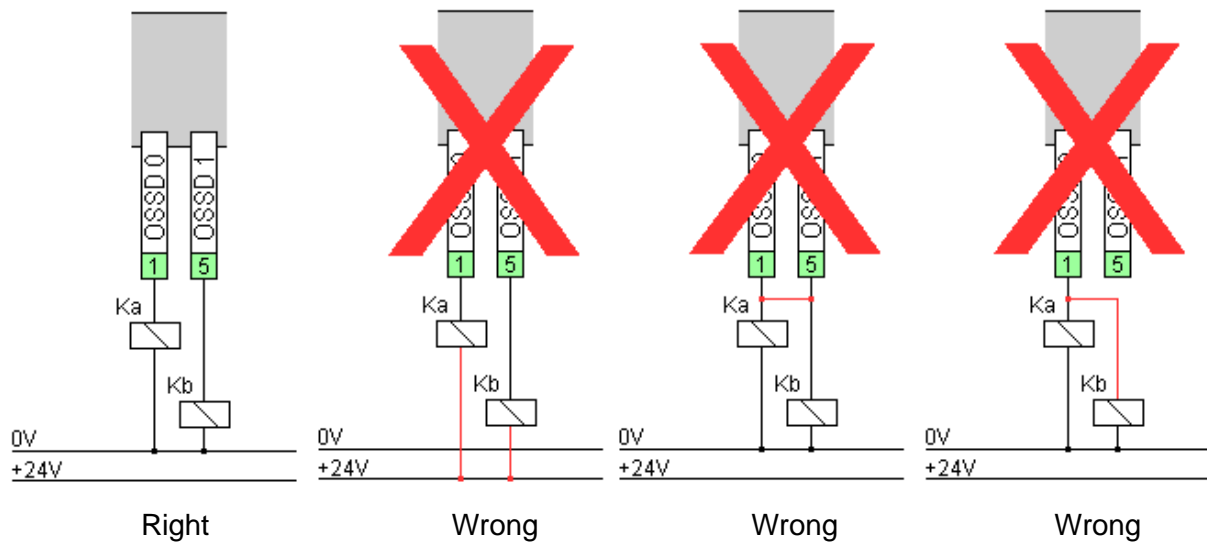

**EDM**

If an error occurs on the EDM function, OS OFF and FAULT indicators are ON and ALN3 indicator blinks. The light curtain is locked. Turn OFF the barrier, check the EDM connections and then turn ON the power supply.

The main causes can be :

- wire not connected or connected to 0V;
- contact of external device open when the barrier is in OFF state;
- voltage to external device not present or not correct;
- external contactor defective.

In Manual reset if the safety conditions are met the BMS indicator is ON. Press and release the RESTART push button to activate the barrier.

In Automatic reset if the safety conditions are met the barrier will be activated.

In the case that the external contactors are not connected directly to the barrier, and do not switch when the OSSDs pass in the ON state, the barrier goes cyclically into the OFF state for 15 seconds, and after, if the conditions allow it, resumes the ON state testing again the EDM input.

**If the EDM is not used, connect it to the OSSD 0 output.**

## ATTENTION

Each repair operation should be performed only by GREIN authorized technicians.

## SERVICE AND TEST

### Putting into service and tests at regular intervals

The installer that put the equipment into service shall have all necessary information about the machine or the plant, and the installed ESPE EFESTO-SZ.

The testing shall cover the correct interaction of the ESPE and the control system of the power-operated working equipment, the safe state, and the construction in compliance with the equipment-specific safety rules. The test-relevant information provided by the machine or plant manufacturer (e.g. a press manufacturer) shall always be observed when testing.

A distinction is made between the following types of test:

### Testing prior to put a device into service for the first time and after modifications (approval tests)

An authorized, qualified person should test the ESPE prior to its being put into service for the first time, and after its - or its components / units involved in the safety function - having been modified.

All changes of the circuit/switching, the control system, the ESPE configuration and the involved components/units affecting the safety function are considered a modification.

Those tests are to determine that the power-operated working equipment (e.g. the press) fulfils the requirements when the ESPE is employed, and that the correct operation of the components/units involved in the safety function is ensured for the interaction with the ESPE. Furthermore, type of use and installation of the ESPE shall be tested.

### Periodical tests

Periodical tests serve the purpose of systematically detecting and removing safety-relevant deficiencies (e.g. in the event of modification or manipulation) of the protective equipment of the machine or facility which occur after the machine/facility having been put into service. Type, scope and time intervals to be followed are listed in clause "**SETTING UP AND TEST**" of the ESPE's instructions for use and shall be determined and specified for each individual working equipment (e.g. for a press). Furthermore, the prerequisites (e.g. qualified person, expert) to be fulfilled by the appointed person are to be specified.

The testing includes a safety check of the correct functioning of the ESPE, the condition of the components, the correct installation of the ESPE, and the interaction of the ESPE with the control system of the press. The test results shall be recorded and written in a report which is to be signed by the inspector. The report shall be kept at the installation site of the machine or facility, respectively.

### Maintenance

Periodically clean the front of the barriers using a soft damp cloth.

Do not use solvents or abrasive products, as this may tarnish the front protection.

For particularly hostile environments where very intense cleaning is required, it is possible to request glass front protection instead of polycarbonate when ordering, which allows the use of more aggressive solvents.



## SETTING UP AND TEST

### FINAL CHECK BEFORE STARTING

Before connecting the curtain to the power supply, ensure that:

- the value of power supply is 24 Vdc ;
- connection cables of emitter and receiver to machine are correct ;

When the barrier is aligned, if AUTOMATIC RESTART is set, the OS ON indicator will turn ON and the 24 V is present on OSSDs outputs. Otherwise, if the MANUAL RESTART is set, the BMS indicator is ON and OS ON is OFF, then press and release the START button to activate the barrier ( 24 V is present on OSSDs outputs, BMS is OFF and OS ON is ON ).

Performing the periodical test follow the verifications listed below:

**Hint: to ensure higher safety level, perform these tests in manual reset.**

Daily testing of the protective device by authorized personnel.

By the operator, daily or prior to each work session by means of complete coverage of every beam of light using the test rod. The test rod is supplied up to 40 mm resolution.

Move the test rod slowly through the length of the protective field at three different points:

- 1) Protective field limits / protective field markings close to sender (access opening).
- 2) Protective field limits / protective field markings close to receiver.
- 3) Protective field limits in middle between transmitter and receiver.

During the test, the BMS indicator must be turned OFF. If during this test the BMS indicator is lights up, it is necessary to verify the mechanical installation in accordance with the minimum distance to avoid the reflecting signal as reported in page 9.

Check for damage to the protective device, the mounting, electrical connection.

Check for wear or damage to the housing, front screen, or electrical connection cable.

Check that people or body parts can only access the danger zone through the protective field.

If one or more errors occur during the test, the machine must be shut down.

Now the light curtain is ready for working.

### List of models and characteristics

The images describe the main parameters considered in the selection of light curtain, in the following pages are shown the complete list of barriers "EFESTO-SZ" series.

**Total height.** Total height. To estimate the total height of the barrier, check the column H ( barrier height ) in table below and add the connector height how show in the figure below.

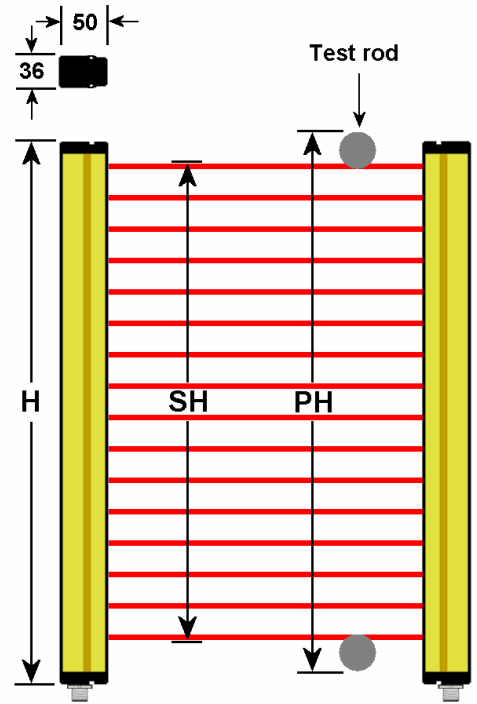

### Minimum dimensions for the connection

It is necessary to provide a minimum space for the connector, refer to figure below.

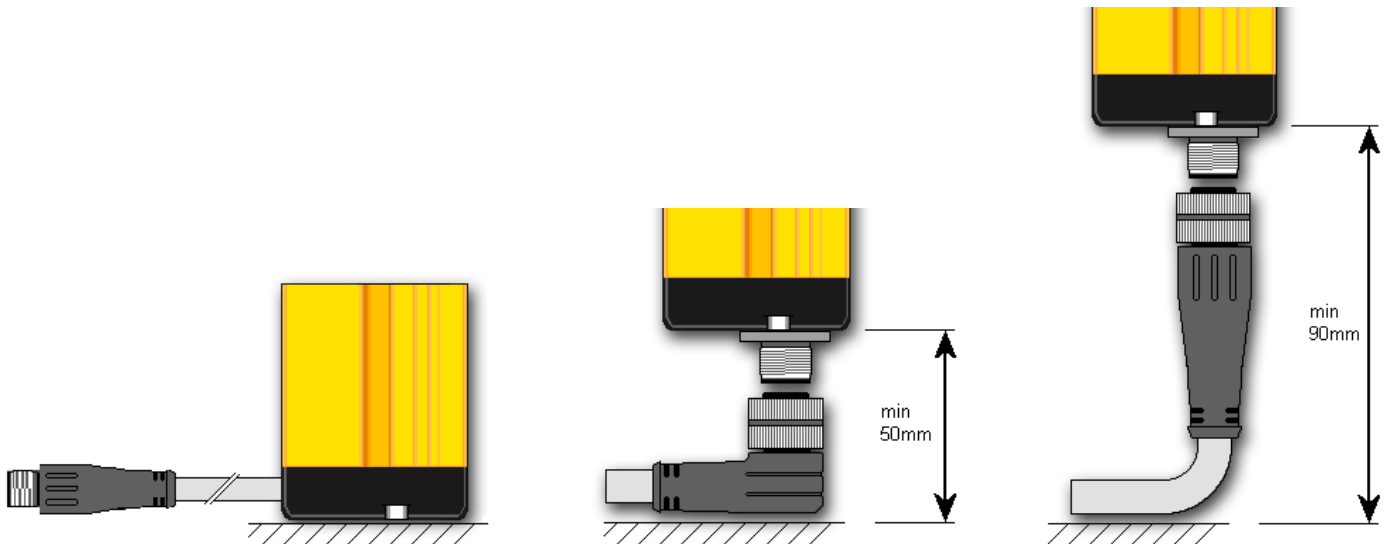

M12 Rear Cable

M12 angle

M12 right

**Special size.** If the standard barriers do not satisfy the customer application, our technical office will evaluate the possibility to produce a custom model.

Resolution 14 mm Range 0.6 m Optical code "A"								
Model	N° of beams	Protected Height PH ( mm )	Sensitive Height SH ( mm )	Barrier Height H ( mm )	Weight (Tx+RX) ( Kg )	Response Time ( ms )	Mtff ( years )	PL
EFSZ -x - 0120 A	12	134	114	218	0.8	6	100	e
EFSZ -x - 0180 A	18	194	174	218	0.9	6	100	e
EFSZ -x - 0240 A	24	254	234	280	1.1	6	100	e
EFSZ -x - 0300 A	30	314	294	340	1.4	11	100	e
EFSZ -x - 0360 A	36	374	354	400	1.7	11	100	e
EFSZ -x - 0420 A	42	434	414	460	1.9	11	100	e
EFSZ -x - 0480 A	48	494	474	520	2.1	11	100	e
EFSZ -x - 0540 A	54	554	534	580	2.3	11	100	e
EFSZ -x - 0600 A	60	614	594	640	2.5	11	100	e
EFSZ -x - 0660 A	66	674	654	7000	2.7	11	96.2	e
EFSZ -x - 0700 A	72	734	714	760	3.0	16	90.8	e
EFSZ -x - 0780 A	78	794	774	820	3.2	16	85.9	e
EFSZ -x - 0850 A	84	854	834	880	3.4	16	81.6	e
EFSZ -x - 0900 A	90	914	894	940	3.6	16	77.6	e
EFSZ -x - 0950 A	96	974	954	1000	3.8	16	74.1	e
EFSZ -x - 1100 A	108	1094	1074	1120	4.2	16	67.8	e
EFSZ -x - 1200 A	120	1214	1194	1240	4.7	21	62.5	e
EFSZ -x - 1300 A	132	1334	1314	1360	5.1	21	58.0	e
EFSZ -x - 1400 A	144	1454	1434	1480	5.5	21	54.1	e
EFSZ -x - 1500 A	156	1574	1554	1600	5.9	26	50.7	e
EFSZ -x - 1700 A	168	1694	1674	1720	6.4	26	47.7	e
EFSZ -x - 1800 A	180	1814	1794	1840	6.8	26	45.0	e
EFSZ -x - 1900 A	192	1934	1914	1960	7.2	31	42.6	e
EFSZ -x - 2000 A	204	2054	2034	2080	7.6	31	40.4	e
EFSZ -x - 2200 A	216	2174	2154	2200	8.1	31	38.5	e
EFSZ -x - 2300 A	228	2294	2274	2320	8.5	31	36.7	e

Resolution 20 mm Range 2.15 m Optical code "AL"								
Model	N° of beams	Protected Height PH ( mm )	Sensitive Height SH ( mm )	Barrier Height H ( mm )	Weight (Tx+RX) ( Kg )	Response Time ( ms )	Mtff ( years )	PL
EFSZ -x - 0120 AL	12	140	120	218	0.8	6	100	e
EFSZ -x - 0180 AL	18	200	180	218	0.9	6	100	e
EFSZ -x - 0240 AL	24	260	240	280	1.1	6	100	e
EFSZ -x - 0300 AL	30	320	300	340	1.4	11	100	e
EFSZ -x - 0360 AL	36	380	360	400	1.7	11	100	e
EFSZ -x - 0420 AL	42	440	420	460	1.9	11	100	e
EFSZ -x - 0480 AL	48	500	480	520	2.1	11	100	e
EFSZ -x - 0540 AL	54	560	540	580	2.3	11	100	e
EFSZ -x - 0600 AL	60	620	600	640	2.5	11	100	e
EFSZ -x - 0660 AL	66	680	660	700	2.7	11	96.2	e
EFSZ -x - 0700 AL	72	740	720	760	3.0	16	90.8	e
EFSZ -x - 0780 AL	78	800	780	820	3.2	16	85.9	e
EFSZ -x - 0850 AL	84	860	840	880	3.4	16	81.6	e
EFSZ -x - 0900 AL	90	920	900	940	3.6	16	77.6	e
EFSZ -x - 0950 AL	96	980	960	1000	3.8	16	74.1	e
EFSZ -x - 1100 AL	108	1100	1080	1120	4.2	16	67.8	e
EFSZ -x - 1200 AL	120	1220	1200	1240	4.7	21	62.5	e
EFSZ -x - 1300 AL	132	1340	1320	1360	5.1	21	58.0	e
EFSZ -x - 1400 AL	144	1460	1440	1480	5.5	21	54.1	e
EFSZ -x - 1500 AL	156	1580	1560	1600	5.9	26	50.7	e
EFSZ -x - 1700 AL	168	1700	1680	1720	6.4	26	47.7	e
EFSZ -x - 1800 AL	180	1820	1800	1840	6.8	26	45.0	e
EFSZ -x - 1900 AL	192	1940	1920	1960	7.2	31	42.6	e
EFSZ -x - 2000 AL	204	2060	2040	2080	7.6	31	40.4	e
EFSZ -x - 2200 AL	216	2180	2160	2200	8.1	31	38.5	e
EFSZ -x - 2300 AL	228	2300	2280	2320	8.5	31	36.7	e

Resolution 30 mm Range 0,5 .. 15 m Optical code "B"								
Model	N° of beams	Protected Height PH ( mm )	Sensitive Height SH ( mm )	Barrier Height H ( mm )	Weight (Tx+RX) ( Kg )	Response Time ( ms )	Mtff ( years )	PL
EFSZ -x - 0150 B	6	174	126	215	0.8	6	100	e
EFSZ -x - 0210 B	8	222	174	225	0.9	6	100	e
EFSZ -x - 0240 B	9	246	198	250	1.0	6	100	e
EFSZ -x - 0300 B	12	318	270	322	1.2	6	100	e
EFSZ -x - 0360 B	14	366	318	370	1.3	6	100	e
EFSZ -x - 0390 B	15	390	342	394	1.4	6	100	e
EFSZ -x - 0450 B	18	462	414	466	1.6	6	100	e
EFSZ -x - 0540 B	21	534	486	538	1.8	6	100	e
EFSZ -x - 0600 B	24	606	558	610	2.0	6	100	e
EFSZ -x - 0680 B	27	678	630	682	2.4	11	100	e
EFSZ -x - 0750 B	30	750	702	754	2.4	11	100	e
EFSZ -x - 0820 B	33	822	774	826	2.6	11	100	e
EFSZ -x - 0900 B	36	894	846	898	2.8	11	100	e
EFSZ -x - 0970 B	39	966	918	970	3.0	11	100	e
EFSZ -x - 1050 B	42	1038	990	1042	3.2	11	100	e
EFSZ -x - 1100 B	45	1110	1062	1114	3.4	11	100	e
EFSZ -x - 1200 B	48	1182	1134	1186	3.6	11	100	e
EFSZ -x - 1250 B	51	1254	1206	1258	3.8	11	100	e
EFSZ -x - 1350 B	54	1326	1278	1330	4.0	11	100	e
EFSZ -x - 1400 B	57	1398	1350	1402	4.2	11	100	e
EFSZ -x - 1500 B	60	1470	1422	1474	4.4	11	100	e
EFSZ -x - 1650 B	66	1614	1566	1618	4.8	11	100	e
EFSZ -x - 1800 B	72	1758	1710	1762	5.2	16	100	e
EFSZ -x - 1950 B	78	1902	1854	1906	5.6	16	100	e
EFSZ -x - 2100 B	84	2046	1998	2050	6.0	16	100	e
EFSZ -x - 2200 B	90	2190	2142	2194	6.4	16	100	e
EFSZ -x - 2300 B	96	2334	2286	2338	6.8	16	100	e
EFSZ -x - 2450 B	102	2478	2430	2482	7.2	16	100	e
EFSZ -x - 2650 B	108	2622	2574	2626	7.6	16	99.18	e
EFSZ -x - 2750 B	114	2776	2718	2770	8.0	21	97.15	e
EFSZ -x - 2900 B	120	2910	2862	2914	8.4	21	95.21	e
EFSZ -x - 3000 B	126	3054	3006	3058	8.8	21	93.35	e

Resolution 40 mm Range 6 .. 30 m Optical code "BL"								
Model	N° of beams	Protected Height PH ( mm )	Sensitive Height SH ( mm )	Barrier Height H ( mm )	Weight (Tx+RX) ( Kg )	Response Time ( ms )	Mtff ( years )	PL
EFSZ -x - 0150 BL	6	185	135	215	0.8	6	100	e
EFSZ -x - 0210 BL	8	233	183	225	0.9	6	100	e
EFSZ -x - 0240 BL	9	257	207	250	1.0	6	100	e
EFSZ -x - 0300 BL	12	329	279	322	1.2	6	100	e
EFSZ -x - 0360 BL	14	377	327	370	1.3	6	100	e
EFSZ -x - 0390 BL	15	401	351	394	1.4	6	100	e
EFSZ -x - 0450 BL	18	473	423	466	1.6	6	100	e
EFSZ -x - 0540 BL	21	545	495	538	1.8	6	100	e
EFSZ -x - 0600 BL	24	617	567	610	2.0	6	100	e
EFSZ -x - 0680 BL	27	689	639	682	2.4	11	100	e
EFSZ -x - 0750 BL	30	761	711	754	2.4	11	100	e
EFSZ -x - 0820 BL	33	833	783	826	2.6	11	100	e
EFSZ -x - 0900 BL	36	905	855	898	2.8	11	100	e
EFSZ -x - 0970 BL	39	977	927	970	3.0	11	100	e
EFSZ -x - 1050 BL	42	1049	999	1042	3.2	11	100	e
EFSZ -x - 1100 BL	45	1121	1071	1114	3.4	11	100	e
EFSZ -x - 1200 BL	48	1193	1143	1186	3.6	11	100	e
EFSZ -x - 1250 BL	51	1265	1215	1258	3.8	11	100	e
EFSZ -x - 1350 BL	54	1337	1287	1330	4.0	11	100	e
EFSZ -x - 1400 BL	57	1409	1359	1402	4.2	11	100	e
EFSZ -x - 1500 BL	60	1481	1431	1474	4.4	11	100	e
EFSZ -x - 1650 BL	66	1625	1575	1618	4.8	11	100	e
EFSZ -x - 1800 BL	72	1769	1719	1762	5.2	16	100	e
EFSZ -x - 1950 BL	78	1913	1863	1906	5.6	16	100	e
EFSZ -x - 2100 BL	84	2057	2007	2050	6.0	16	100	e
EFSZ -x - 2200 BL	90	2201	2151	2194	6.4	16	100	e
EFSZ -x - 2300 BL	96	2345	2295	2338	6.8	16	100	e
EFSZ -x - 2450 BL	102	2489	2439	2482	7.2	16	100	e
EFSZ -x - 2650 BL	108	2633	2583	2626	7.6	16	99.18	e
EFSZ -x - 2750 BL	114	2777	2727	2770	8.0	21	97.15	e
EFSZ -x - 2900 BL	120	2921	2871	2914	8.4	21	95.21	e
EFSZ -x - 3000 BL	126	3065	3015	3058	8.8	21	93.35	e

Resolution 55 mm Range 0,5 .. 15 m Optical code "C"								
Model	N° of beams	Protected Height PH ( mm )	Sensitive Height SH ( mm )	Barrier Height H ( mm )	Weight (Tx+RX) ( Kg )	Response Time ( ms )	Mtff ( years )	PL
EFSZ -x - 0150 C	3	200	102	215	0.8	6	100	e
EFSZ -x - 0250 C	5	296	198	250	1.1	6	100	e
EFSZ -x - 0300 C	6	344	246	322	1.2	6	100	e
EFSZ -x - 0400 C	8	440	342	394	1.5	6	100	e
EFSZ -x - 0450 C	9	488	390	466	1.6	6	100	e
EFSZ -x - 0600 C	12	632	534	610	2.0	6	100	e
EFSZ -x - 0750 C	15	776	678	754	2.4	6	100	e
EFSZ -x - 0900 C	18	920	822	898	2.8	6	100	e
EFSZ -x - 1050 C	21	1064	966	1042	3.2	6	100	e
EFSZ -x - 1200 C	24	1208	1110	1186	3.6	6	100	e
EFSZ -x - 1350 C	27	1352	1254	1330	4.0	11	100	e
EFSZ -x - 1500 C	30	1496	1398	1474	4.4	11	100	e
EFSZ -x - 1650 C	33	1640	1542	1618	4.8	11	100	e
EFSZ -x - 1800 C	36	1784	1686	1762	5.2	11	100	e
EFSZ -x - 1950 C	39	1928	1830	1906	5.6	11	100	e
EFSZ -x - 2100 C	42	2072	1974	2050	6.0	11	100	e
EFSZ -x - 2200 C	45	2216	2118	2194	6.4	11	100	e
EFSZ -x - 2300 C	48	2360	2262	2338	6.8	11	100	e
EFSZ -x - 2450 C	51	2504	2406	2482	7.2	11	100	e
EFSZ -x - 2650 C	54	2648	2550	2626	7.6	11	100	e
EFSZ -x - 2750 C	57	2792	2694	2770	8.0	11	100	e
EFSZ -x - 2900 C	60	2936	2838	2914	8.4	11	100	e
EFSZ -x - 3000 C	63	3080	2982	3058	8.8	11	100	e

Resolution 65 mm Range 6 .. 30 m Optical code "CL"								
Model	N° of beams	Protected Height PH ( mm )	Sensitive Height SH ( mm )	Barrier Height H ( mm )	Weight (Tx+RX) ( Kg )	Response Time ( ms )	Mtff ( years )	PL
EFSZ -x - 0150 CL	3	211	111	215	0.8	6	100	e
EFSZ -x - 0250 CL	5	307	207	250	1.1	6	100	e
EFSZ -x - 0300 CL	6	355	255	322	1.2	6	100	e
EFSZ -x - 0400 CL	8	451	351	394	1.5	6	100	e
EFSZ -x - 0450 CL	9	499	399	466	1.6	6	100	e
EFSZ -x - 0600 CL	12	643	543	610	2.0	6	100	e
EFSZ -x - 0750 CL	15	787	687	754	2.4	6	100	e
EFSZ -x - 0900 CL	18	931	831	898	2.8	6	100	e
EFSZ -x - 1050 CL	21	1075	975	1042	3.2	6	100	e
EFSZ -x - 1200 CL	24	1219	1119	1186	3.6	6	100	e
EFSZ -x - 1350 CL	27	1363	1263	1330	4.0	11	100	e
EFSZ -x - 1500 CL	30	1507	1407	1474	4.4	11	100	e
EFSZ -x - 1650 CL	33	1651	1551	1618	4.8	11	100	e
EFSZ -x - 1800 CL	36	1795	1695	1762	5.2	11	100	e
EFSZ -x - 1950 CL	39	1939	1839	1906	5.6	11	100	e
EFSZ -x - 2100 CL	42	2083	1983	2050	6.0	11	100	e
EFSZ -x - 2200 CL	45	2227	2127	2194	6.4	11	100	e
EFSZ -x - 2300 CL	48	2371	2271	2338	6.8	11	100	e
EFSZ -x - 2450 CL	51	2515	2415	2482	7.2	11	100	e
EFSZ -x - 2650 CL	54	2659	2559	2626	7.6	11	100	e
EFSZ -x - 2750 CL	57	2803	2703	2770	8.0	11	100	e
EFSZ -x - 2900 CL	60	2947	2847	2914	8.4	11	100	e
EFSZ -x - 3000 CL	63	3091	2991	3058	8.8	11	100	e

Resolution 125 mm Range 0,5 .. 15 m Optical code "D"							
Model	N° of beams	Sensitive Height SH ( mm )	Barrier Height H ( mm )	Weight (Tx+RX) ( Kg )	Response Time ( ms )	Mtff ( years )	PL
EFSZ - x - 0350 D	4	366	418	1.6	6	100	e
EFSZ - x - 0600 D	6	606	658	2.8	6	100	e
EFSZ - x - 0850 D	8	846	898	3.2	6	100	e
EFSZ - x - 1050 D	10	1086	1138	4.2	6	100	e
EFSZ - x - 1350 D	12	1326	1378	4.8	6	100	e
EFSZ - x - 1550 D	14	1566	1618	5.4	6	100	e
EFSZ - x - 1800 D	16	1806	1858	6.0	6	100	e
EFSZ - x - 2050 D	18	2046	2098	6.6	6	100	e
EFSZ - x - 2250 D	20	2286	2338	7.2	6	100	e
EFSZ - x - 2550 D	22	2526	2578	7.8	6	100	e
EFSZ - x - 2750 D	24	2766	2818	8.4	6	100	e
EFSZ - x - 3050 D	26	3006	3058	9.0	11	100	e

Resolution 135 mm Range 6 .. 30 m Optical code "DL"							
Model	N° of beams	Sensitive Height SH ( mm )	Barrier Height H ( mm )	Weight (Tx+RX) ( Kg )	Response Time ( ms )	Mtff ( years )	PL
EFSZ - x - 0350 DL	4	375	418	1.6	6	100	e
EFSZ - x - 0600 DL	6	615	658	2.8	6	100	e
EFSZ - x - 0850 DL	8	855	898	3.2	6	100	e
EFSZ - x - 1050 DL	10	1095	1138	4.2	6	100	e
EFSZ - x - 1350 DL	12	1335	1378	4.8	6	100	e
EFSZ - x - 1550 DL	14	1575	1618	5.4	6	100	e
EFSZ - x - 1800 DL	16	1815	1858	6.0	6	100	e
EFSZ - x - 2050 DL	18	2055	2098	6.6	6	100	e
EFSZ - x - 2250 DL	20	2295	2338	7.2	6	100	e
EFSZ - x - 2550 DL	22	2535	2578	7.8	6	100	e
EFSZ - x - 2750 DL	24	2775	2818	8.4	6	100	e
EFSZ - x - 3050 DL	26	3015	3058	9.0	11	100	e



Resolution 306 mm Range 0,5 .. 15 m Optical code "E"							
Model	N° of beams	Sensitive Height SH ( mm )	Barrier Height H ( mm )	Weight (Tx+RX) ( Kg )	Response Time ( ms )	Mttf ( years )	PL
EFSZ -x - 0300 E	2	306	408	1.5	6	100	e
EFSZ -x - 0650 E	3	606	708	1.9	6	100	e
EFSZ -x - 0900 E	4	906	1008	3.0	6	100	e
EFSZ -x - 1200 E	5	1206	1308	4.1	6	100	e
EFSZ -x - 1550 E	6	1506	1608	5.2	6	100	e
EFSZ -x - 1800 E	7	1806	1908	6.3	6	100	e
EFSZ -x - 2250 E	8	2106	2208	7.4	6	100	e
EFSZ -x - 2400 E	9	2406	2508	8.5	6	100	e
EFSZ -x - 2750 E	10	2706	2808	9.6	6	100	e
EFSZ -x - 3000 E	11	3006	3108	10.7	6	100	e

Resolution 315 mm Range 6 .. 30 m Optical code "EL"							
Model	N° of beams	Sensitive Height SH ( mm )	Barrier Height H ( mm )	Weight (Tx+RX) ( Kg )	Response Time ( ms )	Mttf ( years )	PL
EFSZ -x - 0300 EL	2	315	408	1.5	6	100	e
EFSZ -x - 0650 EL	3	615	708	1.9	6	100	e
EFSZ -x - 0900 EL	4	915	1008	3.0	6	100	e
EFSZ -x - 1200 EL	5	1215	1308	4.1	6	100	e
EFSZ -x - 1550 EL	6	1515	1608	5.2	6	100	e
EFSZ -x - 1800 EL	7	1815	1908	6.3	6	100	e
EFSZ -x - 2250 EL	8	2115	2208	7.4	6	100	e
EFSZ -x - 2400 EL	9	2415	2508	8.5	6	100	e
EFSZ -x - 2750 EL	10	2715	2808	9.6	6	100	e
EFSZ -x - 3000 EL	11	3015	3108	10.7	6	100	e

### Response time of master / slave configuration

The response time is variable with the number of beams.

In the master / slave configuration, the total response time is calculate as follow :

**Total beams number** = number of the MASTER beams + number of the SLAVE beams

Total beams number	Response Time ms
from 2 up to 24	6
from 25 up to 66	11
from 67 up to 108	16
from 109 up to 150	21
from 151 up to 186	26
from 187 up to 228	31

I.E. - The following configuration of the light curtains produce a response time equal to:

MASTER 90 beams + SLAVE 18 beams total 108 beams Response time = 16 ms

### MTTFd

In the master / slave configuration, the total MTTFd value is obtained by adding the MASTER number beams with the SLAVE number beams. After deriving from " List of the models and the characteristics " tables, the total value of MTTF based on the total number of beams obtained previously.

### BARRIER CODE

		EF - a	450	B	-	-
<b>Model</b>	see table pag 13					
<b>Sensitive height</b>	see table pag 27-33					
<b>Optical code</b>	see table pag 27-33					
<b>Master / Slave *</b>	optional	<b>M</b> = master	<b>S</b> = slave			
<b>Additional indicator</b>	optional	<b>J</b> = end cap LED	<b>D</b> = display slave	<b>P</b> = M12 back cable		

\* suffix available only in the Master / Slave versions.

## ACCESSORIES

### MIRRORS

They are the ideal solution for the protection of area as they protect 2 or 3 sides of the machine reducing the cost of installation. It is possible to resolve the following situations:

- Protection to “ L “ shape when the unit must protect 2 sides with the employ of 1 mirror as fig. 1
- Protection to “ U “ shape when the barrier must protect 3 sides with employ of 2 mirrors as fig. 2
- Total protection when the light curtain protects 4 sides with the employ of 3 mirrors as fig. 3.  
If the perimeter is quite long this solution is not suggested for difficulty of alignment, the best solution is to use 2 barriers and 2 mirrors as shown in fig. 4.

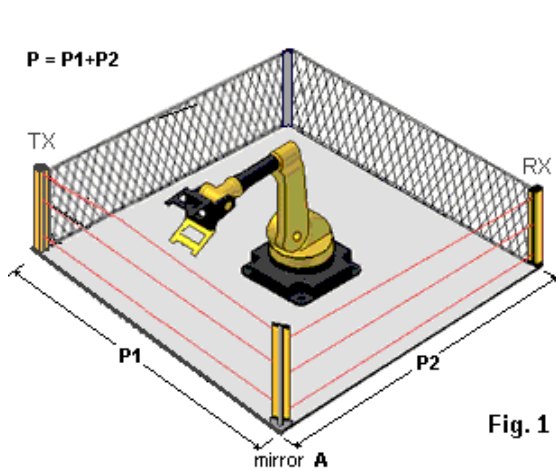

Fig. 1

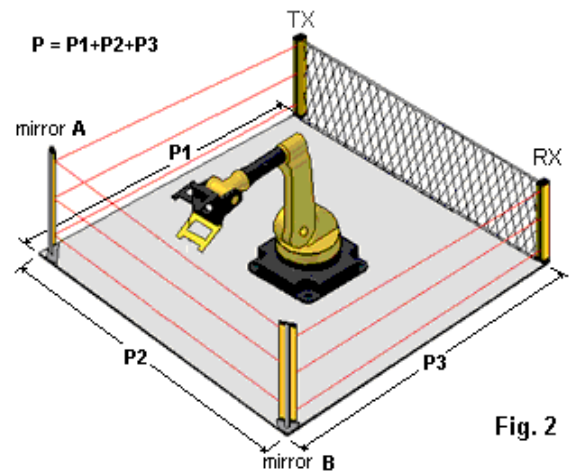

Fig. 2

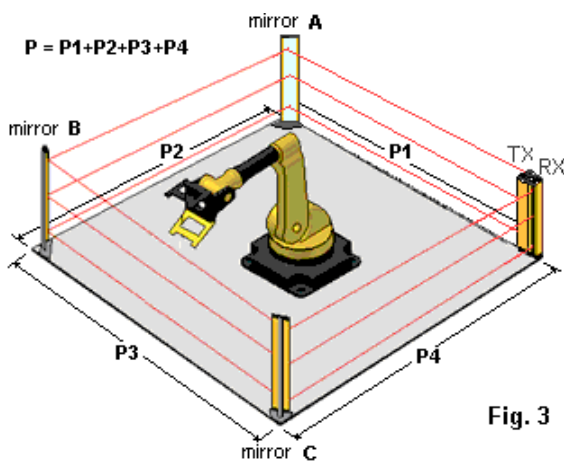

Fig. 3

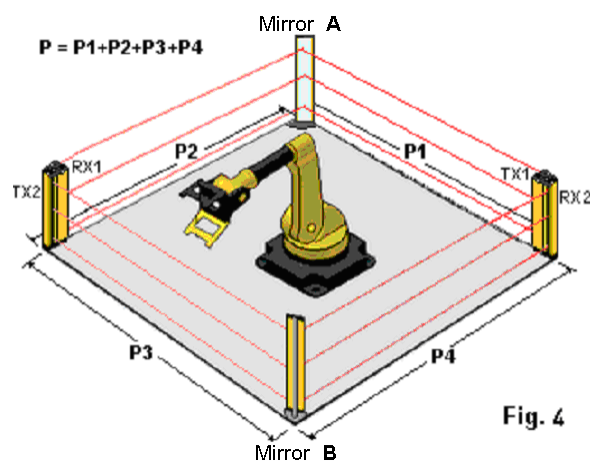

Fig. 4

### Range of curtain using mirrors

The nominal range of the light curtain using these devices will be reduced depending on the number of mirrors, taking into consideration that every mirror reduces the total range by about 25 %. The values of the range are the following:

	Range up to 15 m	Range up to 30 m
Solution fig. 1	P = 12 m	P = 22,5 m
Solution fig. 2	P = 8,5 m	P = 16,5 m
Solution fig. 3	P = 6 m	P = 12 m

### Alignment of barriers using mirrors

- Verify the distance of the sides to protect considering the above data.
- Install the light curtain and the mirrors on the stated points.
- By the adjustments permitted by the brackets set heights of light curtain and verify the verticality of all components.
- Proceed to accurate adjustment as indicated below.

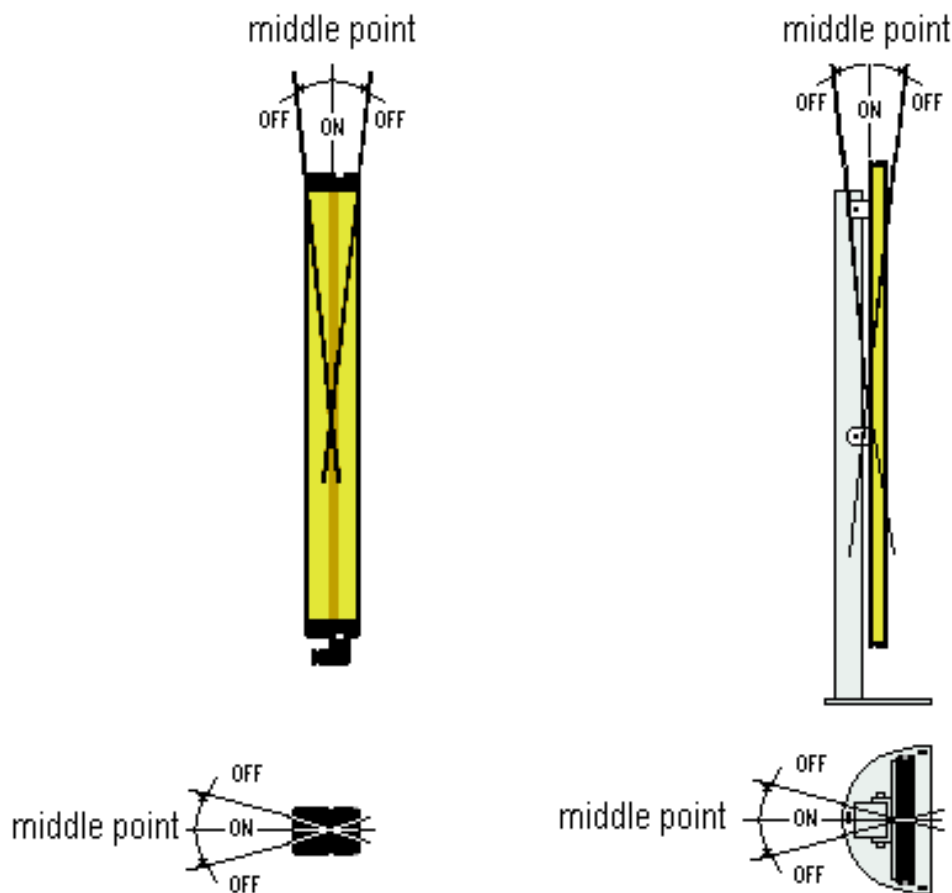

## Application of 1 mirror with two protected sides

Application of 1 mirror for protection of 2 sides

- **First adjustment**

- stand behind the emitter, rotate the mirror until the receiver is visible in the mirror.
- check the verticality of all components.

- **Second adjustment to the tuning**

- stand behind the emitter, rotate the mirror until the receiver is visible in the middle of the mirror.
- Turn on the light curtain and use the "bargraph" for alignment. If the restart is automatic, when the beam is all alignment the OS ON is green, otherwise if the restart is manual the BMS is light on if the beam is all alignment.
- At this point, check the system to render insensible at the vibrations. We must find the middle point as shown in page 36.

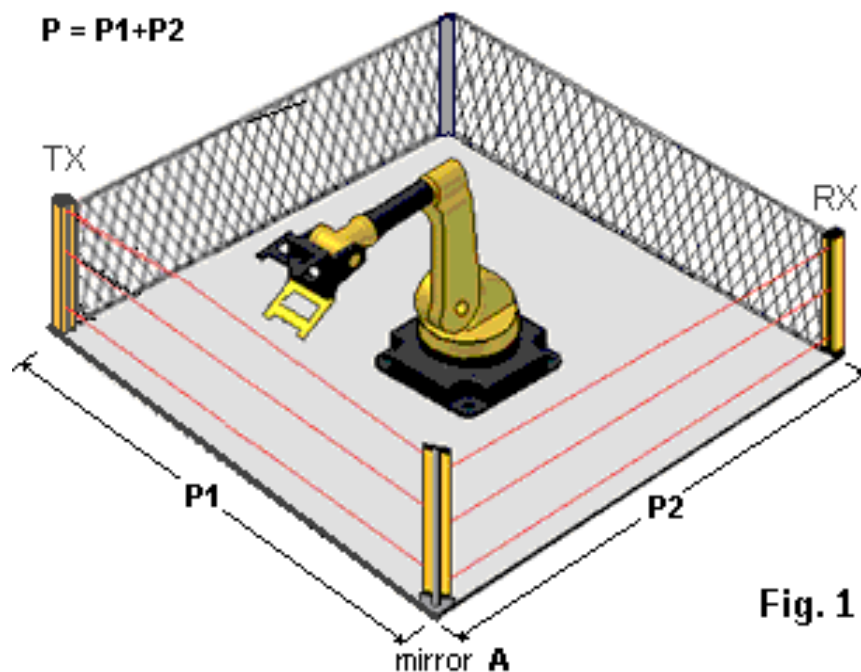

## Application of 2 mirrors with three protected sides

Application of 2 mirrors for protection of 3 sides

### • First adjustment

- place the mirrors on the line of TX or RX unit to center the axis of the beams. Check the distance between the TX and RX with those of the two mirrors and verify the angularity of 90° of each side.
- Place behind the TX and move the mirror A to see the mirror B
- Place behind the RX and move the mirror B to see the mirror A
- check the verticality of all components.

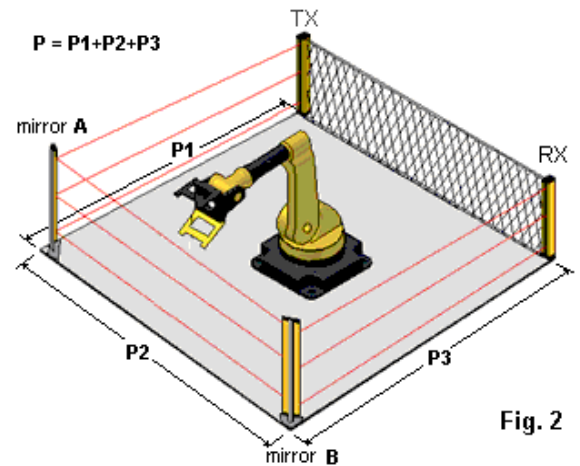

Fig. 2

### • Second adjustment to the tuning

- stand behind the TX, rotate the mirrors until the RX is visible in the middle of the mirror B; stand behind the RX, rotate the mirrors until the TX is visible in the middle of the mirror A
- Turn on the light curtains and use the "bargraph" for alignment. If the restart is automatic, when the beam is all alignment the OS ON is green, otherwise if the restart is manual the BMS is light on if the beam is all alignment.
- At this point, check the system to render insensible at the vibrations. We must find the middle point as shown in page 36.

## Application of 3 mirrors with 4 protected sides

Follow the same procedure as the above point of fig. 2 considering that the centering will be made on 3 mirrors instead of 2. It is quite difficult to align a system using 3 mirrors. For this reason, we suggest using 2 light curtains and 1 mirror or 2 barriers and 2 mirrors depending on the perimeter length needed.

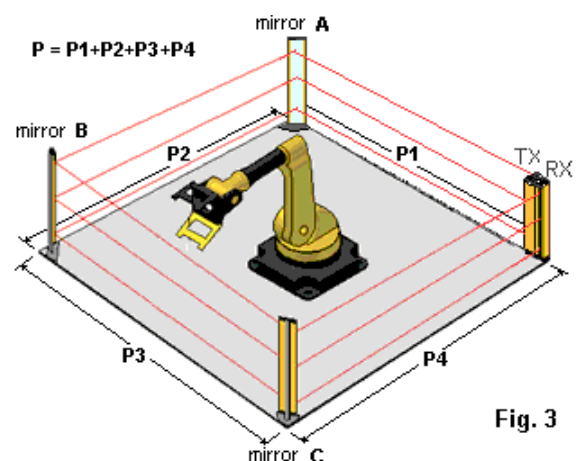

Fig. 3

### Application of 2 mirrors with 2 units

This solution allows to protect the 4 sides as in the previous case, but with the use of two mirrors and two light curtains. The alignment should be done as shown in the first reference (fig.1) but acting independently on two combinations of mirrors / barriers.

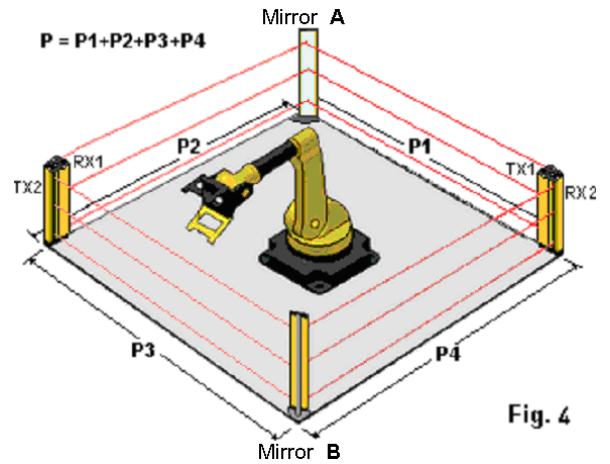
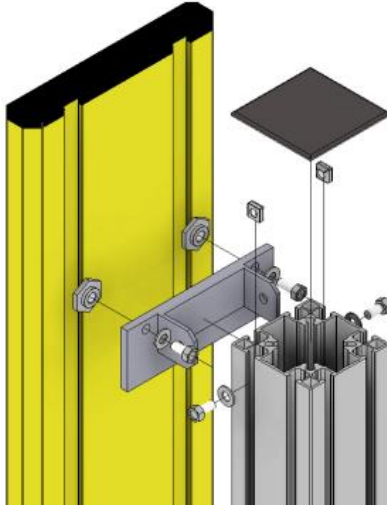
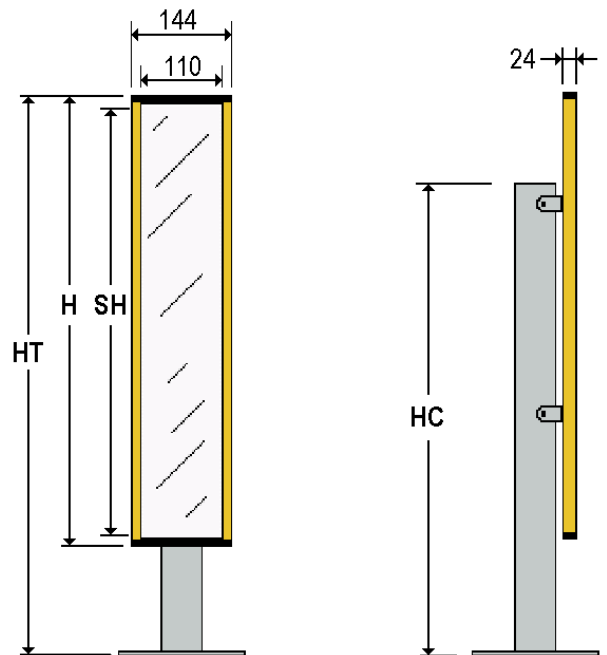
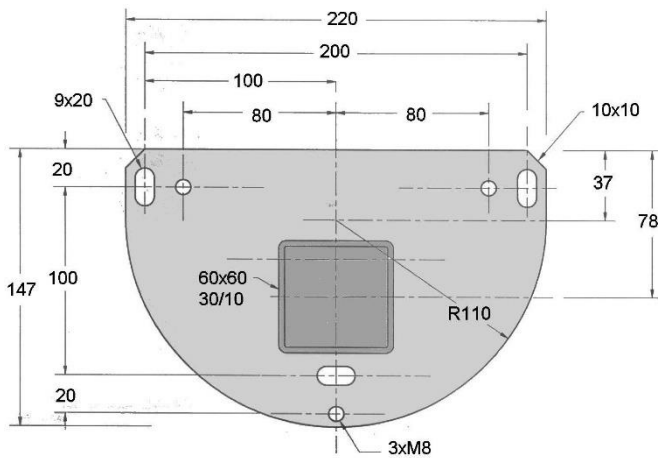

Fig. 4



### DIMENSIONS



### Mirrors and support stand

Mirror			
Model	SH mm	H mm	Code
SCFS 3501	370	390	D-50
SCFS 3502	690	710	D-51
SCFS 3503	1010	1030	D-52
SCFS 3504	1330	1350	D-53
SCFS 3505	1650	1670	D-54
SCFS 3506	1810	1830	D-55
SCFS 3507	1970	1990	D-56

Support stand		
Model	HC mm	Code
SCFS-3021	385	D-60
SCFS-3022	705	D-61
SCFS-3023	1025	D-62
SCFS-3024	1325	D-63
SCFS-3025	1665	D-64
SCFS-3026	1905	D-65

## BRACKETS

### KIT brackets type “STVB”

Supplied as standard with the barrier.

It is the more complete bracket: it is composed from two units (VB1 and VB2) that allow the rotation of the light curtain on the 3 axes to regulate the alignment of TX or RX unit.

They include :

- 4 brackets VB1
- 4 brackets VB2
- 4 washers Ø6
- 4 screws M 6X8
- 8 screws M 5X8

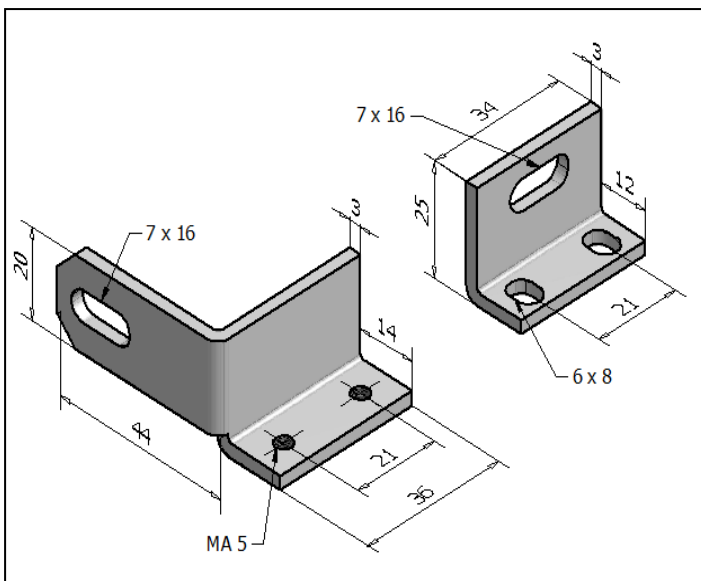

**Brackets type VB1 / VB2**

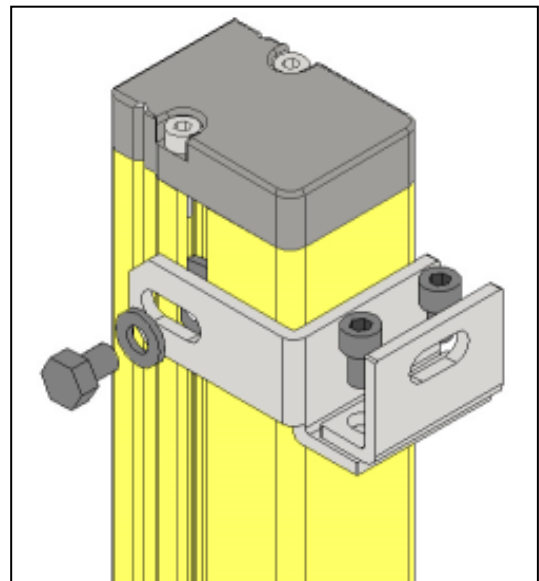

**Brackets STVB assembled**

### NOTE :

To remove the flowing insert ( in order to insert them in the opposite guide of the aluminium enclosure ) you need to remove the end cap without the connector, unscrewing the two screws.



**KIT OF BRACKETS "STGM"**

supplied as optional to STVB kit

Is formed by a one bracket "L" shape that is used for the angular regulation of the barrier. The sliding insert inside the aluminium profile allows the sliding of the light curtain in the height to facilitate its correct positioning.

Content :

- 4 brackets GM
- 4 washers  $\varnothing 6$
- 4 screws M 6X8

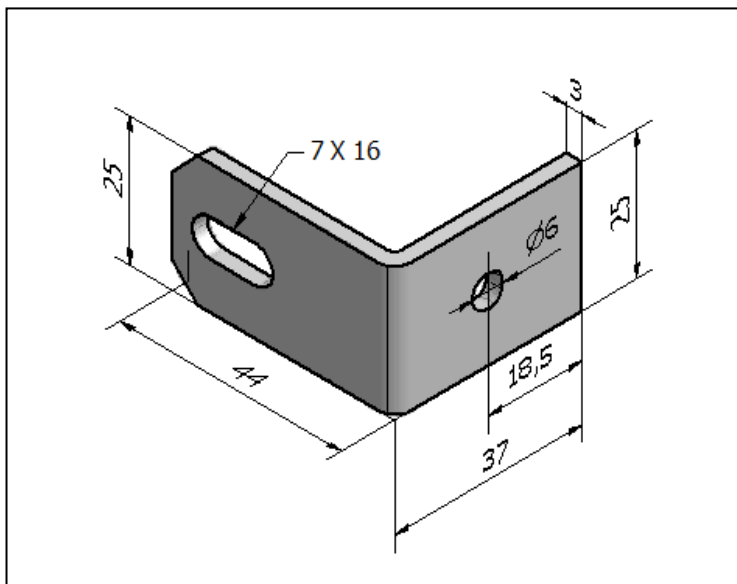

**Brackets type GM**

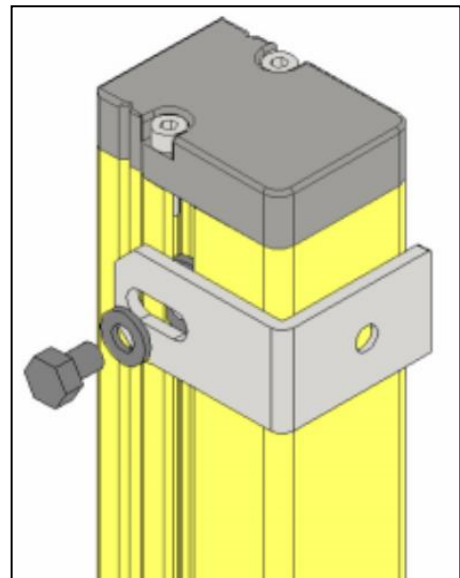

**Brackets STGM mounted**

**NOTE :**

To remove the flowing insert ( in order to insert them in the opposite guide of the aluminium enclosure) you need to remove the end cap without the connector, unscrewing the two screws.

**KIT OF BRACKETS "STDL"**

Supplied on request as alternative to mod. STVB

This brackets kit allows to stay the light curtain in its place established by fixing one of the brackets to the side of the light curtain, is recommended when there are needs or difficulties in the installation of light curtains.

Content:

- 4 brackets type VB1
- 4 brackets type VB3
- 4 washers Ø6
- 4 screws M 6X8
- 8 screws M 5X8

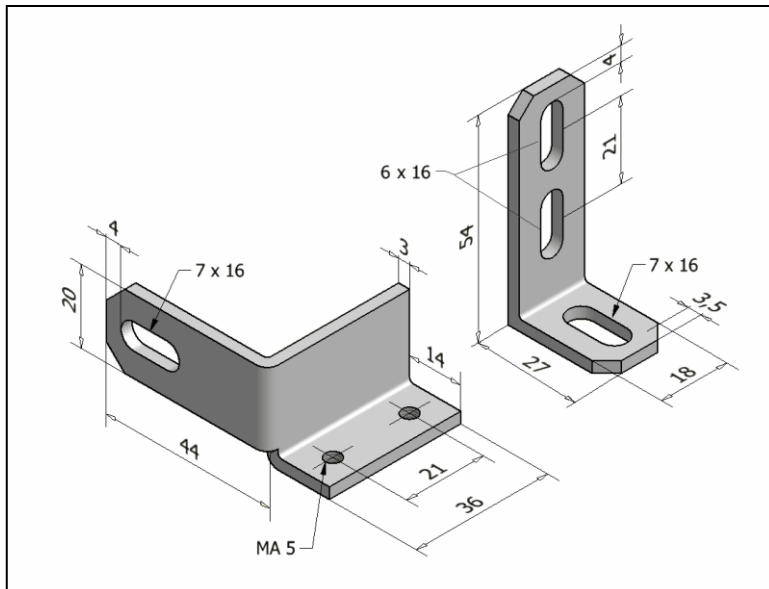

Brackets type VB1 / VB3

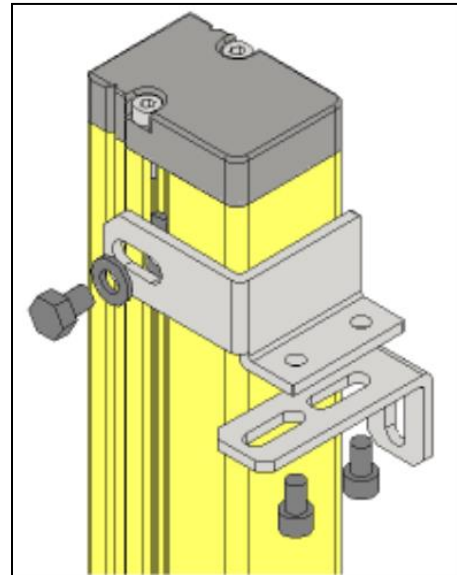

Brackets STDL mounted

**NOTE:**

To remove the flowing insert ( in order to insert them in the opposite guide of the aluminium enclosure) you need to remove the end cap without the connector, unscrewing the two screws.

### CONNECTION CABLES

Description		Code	
<b>Connection cable barrier - cabinet / relay module din rail</b>			
M12 / 4 pins connecting cable, right connector for TX	5m	E-74-05	
	10m	E-74-10	
M12 / 5 pins connecting cable, right connector for RX a	5m	E-75-5	
	10m	E-75-10	
M12 / 8 pins connecting cable, right connector for RX b	5m	E-78-5	
	10m	E-78-10	
<b>Connection cable barrier - external relay module</b>			
M12 / 4 pins cable, 2 female right connector for TX - Rel 021 B	10m	E-104-10	
M12 / 8 pins cable, 2 female right connector for RXb - Rel 021 B	10m	E-108-10	

### INTEGRATED SIGNALLING LAMP

The optional lamp integrated inside the upper end cup of the barrier, provides information on the status of the OSSD



CURTAIN STATE	END CAP LIGHT COLOR
OSSD OFF	RED
OSSD ON	GREEN

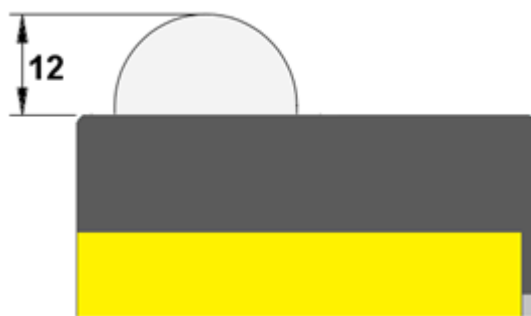

### RELAYS MODULE DIN RAIL

The following box changes the static output of the light curtain, into relays output. This module can be mounted on DIN rail and are matched with light curtain with EDM function **EFSZ-b**.

**REL 011** relay module standard - example of connections with external contactors.

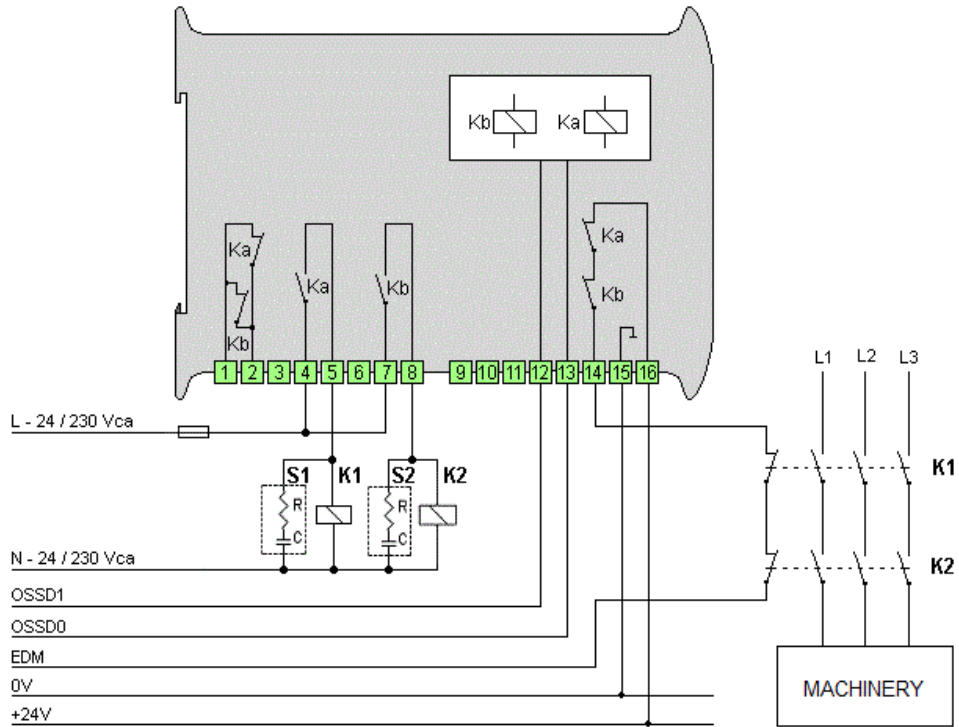

If not used the external contactors control, directly connect the pin 14 to the EDM input of the barrier.

**REL 013** Dual relay module – allows the connection of two barriers

Example of connection of two barriers that control two separate areas of the system by means of contactors. The correct operation of the module and contactors is controlled by the barriers via the EDM input.

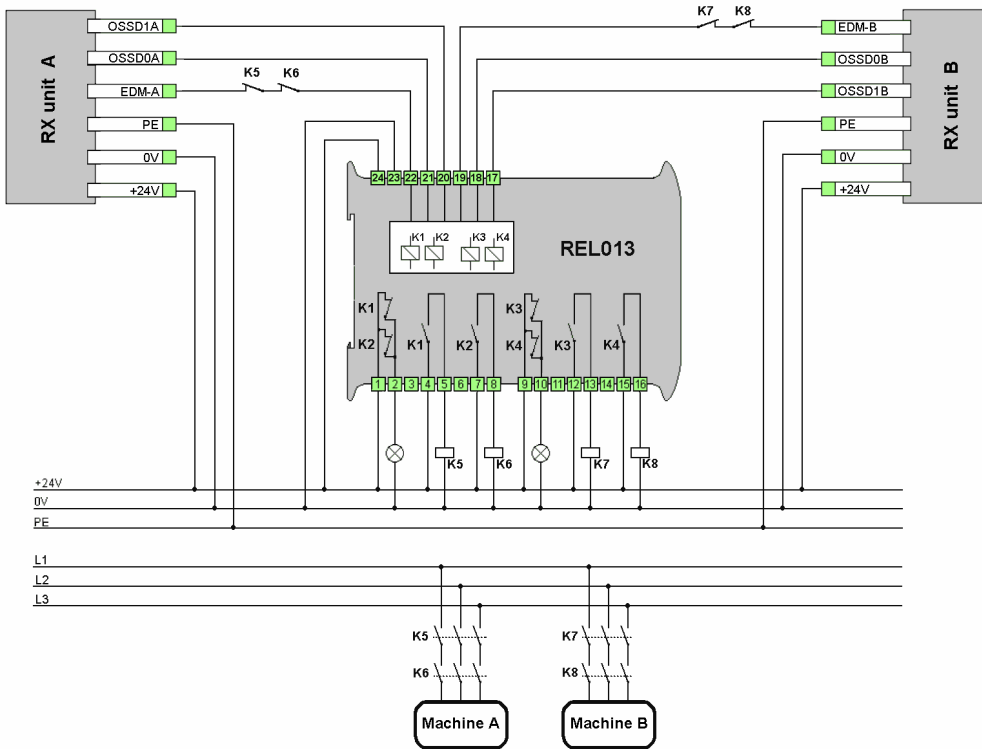

If not used the external contactors control, directly connect the pin 22 to EDM-A and the pin 19 to EDM-B input.

Connection diagram of two barriers that control a single machine (e.g. front-back protection). The correct operation of the module and contactors is checked by the barriers via the EDM inputs

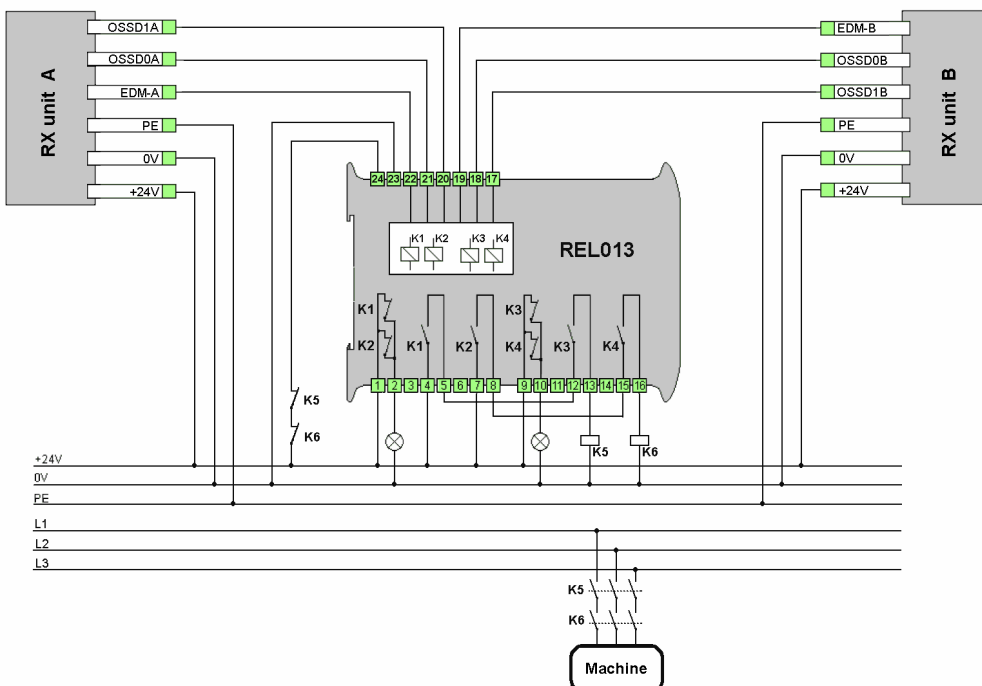

## EXTERNAL RELAY MODULE

**REL 021 B** relays module with spring-key for manual reset and OSSD status lamp for **EFSZ-b**.



Example of connection with external contactor control.

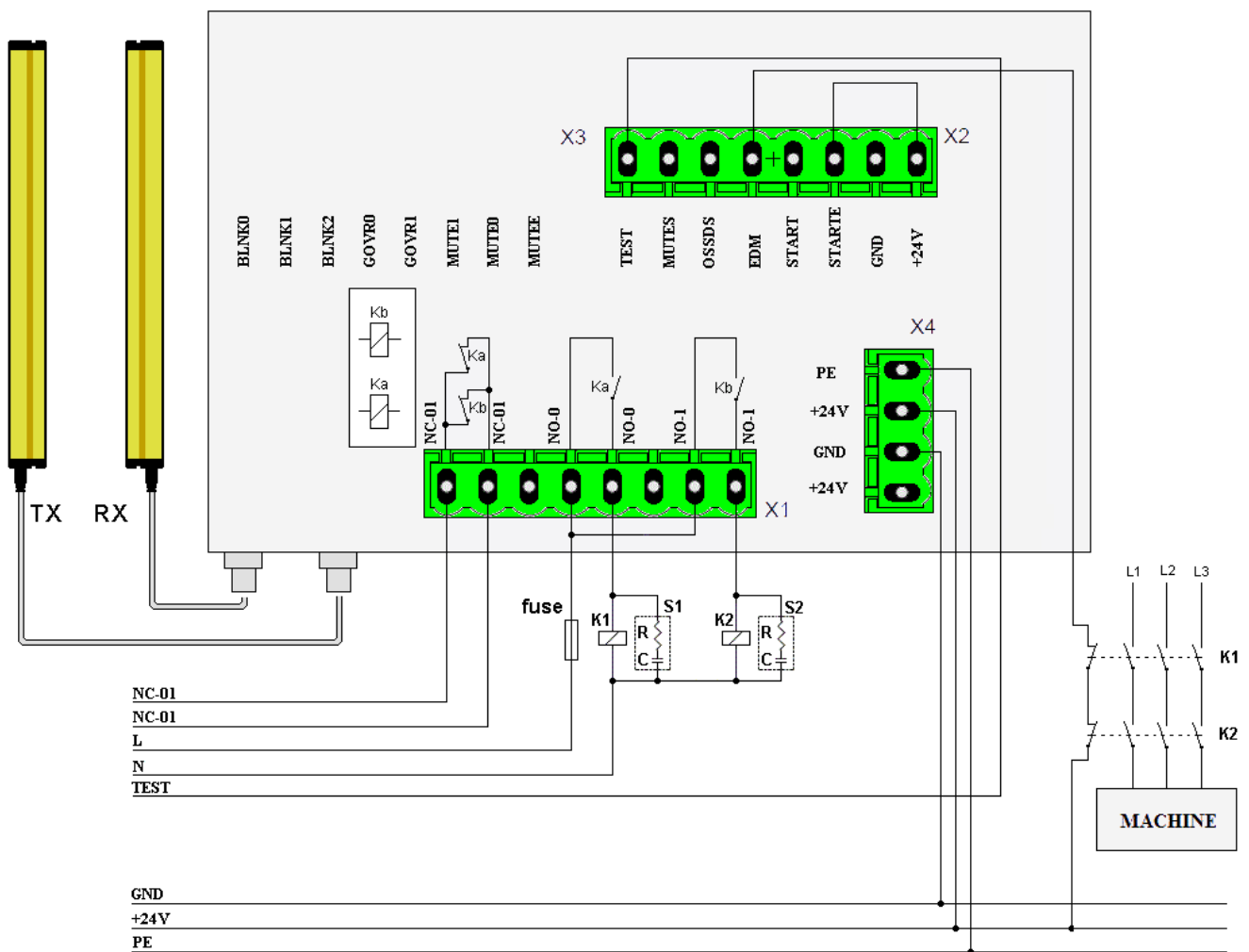

The TEST signal can be led outside to test the safety chain.  
The signal START-E is connected to +24V, so the manual reset is selected.

If not used the external contactors control, connect the EDM input to +24V of X2 connector.

---

## Warranty

---

A guarantee is provided for a period of 12 months from the delivery date and terminates at the expiration of this term, even if the materials have not been used for any reason.

Our company undertakes to repair or replace, during this period, free of charge, within the shortest possible time, those parts which owing to poor quality of material or defective workmanship or inaccurate assembly should prove defective. This is providing that defects are not due to:

- wear and tear
- failure caused by inexperience or negligence
- unauthorized intervention or tampering
- overloads behind contract limits
- accidental causes or "force major"

These repairs or replacements shall be performed AT OUR WORKSHOP in MILANO.  
Transport and workmanship will be completely charged to purchaser.

Nothing will be owed to the purchaser for the time during which the plant may remain idle, nor shall he make claims or ask indemnity for charges, accidents or direct or indirect damages.

For anything else not specified or that becomes a subject of dispute, the ANIE (Italian Electrotechnical Industries Association) general sale conditions will be applied.

**GREIN S.p.A. Milan**

**NOTE: characteristics and dimensions reported in this manual are for reference only and they can be subject to change without notice.**

---

**DICHIARAZIONE “UE” DI CONFORMITA’  
“UE” DECLARATION OF CONFORMITY**

---

**Il fabbricante****The manufacturer****GREIN S.p.A.**

Via S.G.B. De La Salle 4/A 20132 MILANO ITALY

**Dichiara che****Declares that**I prodotti identificati come "EFESTOSZ" sono  
Dispositivi Elettrosensibili di Sicurezza (ESPE)  
Versione 2106 di:The products identified with the name EFESTOSZ"  
are Device for protection of dangerous area (ESPE)  
Version 2106 of:

Tipo 4, SIL 3, Cat 4 – PL e

Type 4, SIL 3, Cat 4 – PL e

**Organismo Notificato****Notified Body****TUV CYPRUS LTD N identificazione 2261****2 Papaflessas str., 2235 Latsia****P.O BOX 20732, 1663 Nicosia****Country : Cyprus****N attestato esame CE del tipo N TÜV CY 22 MD 020567**

Conformi alle seguenti direttive

Conforms to the following directives

2006 / 42 / EC Direttiva Macchine  
come attuata dal DLGS N17 del 27 gen 2010  
2014 / 30 / EC Compatibilità Elettromagnetica  
come attuata dal DLGS N 80 del 18 mag 2016Machine Directive  
Electro Magnetic Compatibility Directive

Norme armonizzate utilizzate

Harmonized standards used

EN 61496-1: 2013, EN 61000-6-2: 2005, EN 61000-6-4: 2007 + A1: 2011  
EN 62061: 2005 + AC: 2010 + A1: 2013 + A2: 2015  
EN ISO 13849-1: 2015, EN ISO 13849-2: 2012

Altre norme e specifiche tecniche utilizzate

Other technical standards and specifications used

EN 61496-2: 2013, EN 61508-3: 2010

Persona autorizzata a costituire il fascicolo tecnico

Person authorized to compile the technical file

Grein S.p.A. Via S.G.B. De La Salle 4/A 20132 MILANO ITALY

NAME Begozzi Roberto  
POSITION C E O GREIN S.p.A.

Milano, 2 January 2023

Originale / Original

La presente dichiarazione di conformità è rilasciata sotto la responsabilità esclusiva del fabbricante  
This declaration of conformity is issued under the sole responsibility of the manufacturer  
**GREIN S.P.A.**  
**Amministratore Unico**



# GREIN



Via S. G. B. De la Salle 4/A 20132 Milano - MI Tel 02 26300140 Fax 02 26300711  
[www.grein.it](http://www.grein.it) | [info@grein.it](mailto:info@grein.it)